

**WITH SOLAX
YOU'VE GOT THE POWER**

SMART SOLAR, STORAGE & ENERGY SOLUTIONS



Scan for digital version



Follow us on social media

SOLAX POWER NETWORK TECHNOLOGY (ZHEJIANG) CO., LTD.

Global: +86 571-56260008

 www.solaxpower.com

 info@solaxpower.com

SOLAX
POWER

WE ARE SOLAX

Established in 2012, SolaX Power is a publicly listed global leader specializing in solar energy storage and smart energy technologies. Offering a comprehensive product portfolio including inverters, batteries, energy storage systems, EV chargers, heat pumps, and integrated smart energy solutions, SolaX serves diverse application scenarios across residential, commercial and industrial, and utility scale projects. With a strong commitment to innovation, driven by an R&D team representing 30% of its workforce, SolaX continues to deliver market-leading solutions worldwide. Dedicated to sustainability and backed by extensive global partnerships, SolaX helps customers in over 110 countries achieve their energy transition goals and significantly reduce carbon emissions.

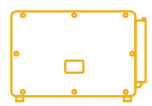

Inverter



Battery

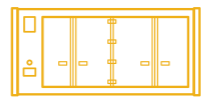

Energy storage system

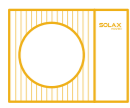

Heat pump



EV charger



Smart energy solution

The Leading Solar Energy Storage Solution Provider

STOCK CODE: 688717.SH

3,000+

Global Employees

1,100+

Global Certifications

1,000+

R&D Personnel

110+

Shipping Countries

1,500,000

Running systems

TIER 1

BloombergNEF
ENERGY STORAGE



reddot



TÜVRheinland®
Precisely Right.



EUPD(2019-2025)

INNOVATION AT OUR CORE

300+ GLOBAL PATENTS

First Hybrid Inverter

2013

R&D Centers

04

R&D Staff

1,000+

R&D Staff Ratio

30%+

ROBUST QUALITY MANAGEMENT SYSTEM

Foundational Management Systems



ISO 9001 – Quality Management System



ISO 14001 – Environmental Management System



ISO 45001 – Occupational Health and Safety Management System

Information Security, Business Continuity & Sustainability Governance



ISO 27001 – Information Security Management System



ISO 22301 – Business Continuity Management System

Green Development and Environmental Responsibility



ISO 50001 – Energy Management System



ISO 14064 – Greenhouse Gas Emissions and Carbon Footprint Management



EPD – Environmental Product Declaration

Corporate Social Responsibility



SA8000 – Social Accountability Management System



ISO 56005 – Innovation Management: Tools and Methods for Intellectual Property Management

Supply Chain Security and Trade Facilitation



AEO Certification – Authorized Economic Operator

SOLAX POWER SMART FACTORY

- LEANIZATION
- DIGITALIZATION
- AUTOMATION

240,000

sqm Manufacturing Land

20GW

Inverter Annual Capacity

10GWh

Battery Annual Capacity

275

Large-scale
Manufacturing Equipments

**PARTNER OF
BORUSSIA DORTMUND**



SOLAX BRAND AMBASSADOR

Highly awarded.

Max can Relax. It's a Solax.



Max Gawn
Melbourne Football Club Captain

CONTENTS

011

OVERVIEW

Overview 011-016

159

SUCCESS STORIES

Success Stories 159-170

017

PRODUCT PORTFOLIO

Plug-and-Play Energy Storage	017-020
Residential Energy Storage HV	021-054
Accessory for Energy Storage	055-070
Residential Energy Storage LV	071-092
Commercial & Industrial Energy Storage	093-120
Utility Energy Storage	121-130
Smart Energy Management	131-142
EV Charger	143-150
Heat Pump	151-158



SOLAX

OVERVIEW

THE LEADING SOLAR ENERGY STORAGE SOLUTION PROVIDER

INNOVATING SINCE 2012

At SolaX Power, our journey in energy storage development has been marked by a relentless commitment to innovation and excellence. Founded with a singular focus on energy storage, SolaX Power boasts a robust R&D department brimming with top-tier talent. We are one of the few companies in the industry with the R&D capability for the synergistic integration of energy storage inverters and batteries, and we excel in mass production of these critical components. Additionally, we possess the ability to independently develop and produce Battery Management Systems (BMS) and continuously optimize the BMS algorithm to enhance the overall performance, reliability, and safety of our energy storage batteries. Our history reflects our unwavering dedication to advancing energy storage technology and delivering superior solutions worldwide.



2013
X-Hybrid inverter G1
(low voltage)



2015
SolaX Box all-in-one ESS



2017
SolaX Box all-in-one ESS G2
AC coupled inverter



2019
Triple Power Battery 5.8kWh G2
A1-ESS G1 for US



2021
X-ESS G4



2023
X3-ULTRA 15-30kW
X-IES 3-15kW



2025
T58 V3



2014
X-Hybrid inverter G2



2016
X-Hybrid inverter G1
(low voltage)

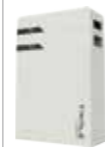

2018
Triple Power Battery
4.5kWh, 6.3kWh G1



2020
J1-ESS for Japan



2022
A1-ESS G2 for US



2024
X3-HYB G4 PRO 4-15kW

5TH Generation of Residential Energy Storage

SOLAX X MATRIX

— Unlock the Power of Intelligence



Five AI Engines Shape the Intelligent Energy Core

XSCHEDULE

— AI Synergy for Energy Scheduling and Trading

The XSCHEDULE panel illustrates a smart home with solar panels on the roof. In the foreground, a smartphone displays an 'Energy Analysis' dashboard with various metrics and a 'Smart Schedule' feature. The background shows a stylized energy waveform.

XCORE & XCOPILOT

— Your Intelligent Foundation and Companion for Energy Management

The XCORE & XCOPILOT panel features a central glowing sphere with an AI icon. Below it, several smartphones display various energy management dashboards and data visualizations, representing the foundation and companion for energy management.

XCARE & XBMS

— Intelligent Protection and Management for System and Battery Core

The XCARE & XBMS panel shows a large, futuristic circular gauge on the left and a smartphone on the right displaying system and battery management data. The background is dark with glowing energy patterns.

- XMonitor — AI Ops
Driven 24/7 Monitoring for Energy Stability
- SOX under AI
AI-Driven SOX Prediction for Smarter Battery Management

Comprehensive Energy Storage Product Series

PLUG-AND-PLAY
ENERGY STORAGE



RESIDENTIAL
ENERGY STORAGE



C&I
ENERGY STORAGE



UTILITY
ENERGY STORAGE





SMART SOLAR, STORAGE & ENERGY SOLUTIONS
Plug-and-Play Energy Storage

All-in-One Balcony ESS

X-MS 2700

2.66 kWh

Features

- Up to 2400W solar input with 4 MPPTs
- All-in-one compact design, plug-and-play installation
- Max charging power 3400 W
- UPS-level switchover time <10ms
- DIY expansion to 16 kWh capacity
- IP65 ingress protection
- Built-in battery heating function, reliable performance in extreme temperature (-20°C)
- Zero waste with self-consumption
- Long-lasting power with 6000 charge cycles
- Support TOU mode to maximize family benefits



X-MS 2700

PV INPUT	
Max. PV input power	2400 W
Max. PV input voltage	60 V
Operation voltage range	16 ~ 60 V
Max. PV input current	18 A
Max. input short circuit current Isc	20 A
No. of MPPT trackers	4
AC ON-GRID	
Rated output apparent power	800 VA*
Rated AC output voltage	220 V / 230 V / 240 V
Rated AC voltage range	180 ~ 276 V
Rated AC frequency	50 Hz / 60 Hz
AC frequency / range	50 ± 5 Hz / 60 ± 5 Hz
Rated output current	3.64 A / 3.48 A / 3.34 A
Power factor range	~ 1 (0.8 leading...0.8 lagging)
Max. AC Input Power	2300 W
Max. Input Current	10 A
AC OFF-GRID	
Rated output power	1000 VA
Peak output apparent power	1600 VA, 10s
Rated AC output voltage	220 V / 230 V / 240 V
Rated AC frequency	50 Hz / 60 Hz
Max. AC output current	7.28 A / 6.96 A / 6.67 A
Max. AC Bypass Output Power	2300 W
BATTERY DATA	
Battery type	LFP
Battery Rated voltage	25.6 V
Battery Rated energy	2662.4 Wh
Battery cycle life	≥ 6000
Rated charging power	1500 W
Rated discharging power	1000 W
GENERAL	
Ingress protection	IP65
Operation temperature range	-20 ~ 55°C
Relative humidity	5 ~ 95% (No Condensing)
Max. operation altitude	3000 m
Dimensions (W x H x D)	480 x 240 x 240 mm
Weight	27 kg
Cooling concept	Natural cooling
Communication	WiFi & Bluetooth
Parallel battery capacity	Up to 5 Units
STANDARD	
Safety	IEC62109-1 / -2
EMC	IEC62619, UN38.3, IEC / EN 61000-6-1, IEC / EN 61000-6-2, IEC / EN 61000-6-3, IEC / EN 61000-6-4, CE-RED
Certifications	VDE4105 / 0124, IEC61727 / 62116, CEI 0 21, EN50549-1, G98, G99, C10-11, UNE217002

* It can be customized by using the Solax App and can be adjusted up to 1000 VA



SMART SOLAR, STORAGE & ENERGY SOLUTIONS
Residential Energy Storage HV

Single-phase Residential Hybrid Inverter



X1-HYBRID G4

3.0kW / 3.7kW / 5.0kW / 6.0kW / 7.5kW

Smart Management

- VPP ready, ancillary service in power market
- Global MPP scan for optimal energy harvest
- Smart loads management (e.g. heat pump, smart EV charger)
- Intelligent ToU-driven energy management
- CT compatibility with fast load response in just 0.3 seconds

High Performance

- 200% PV oversizing and up to 110% AC output
- Up to 200% PV input
- Up to 97% efficiency in charging and discharging
- Low start-up voltage for longer operation

Assured Reliability

- Up to 150% EPS output for 10s
- UPS-level switchover time <10ms
- IP65 Ingress protection
- Type II SPD on AC&DC side

Flexible Adaptability

- Lithium & Lead-acid battery compatible
- Max. 16A DC input current for high power solar panel
- On-grid and off-grid parallel function, up to 15kW

Efficiency Curve

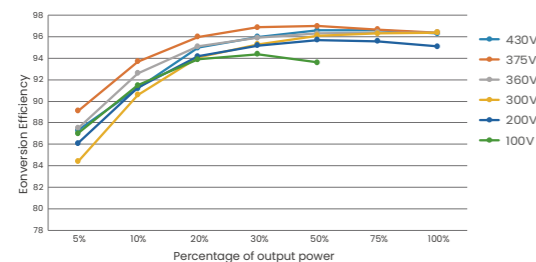

Circuit Diagram

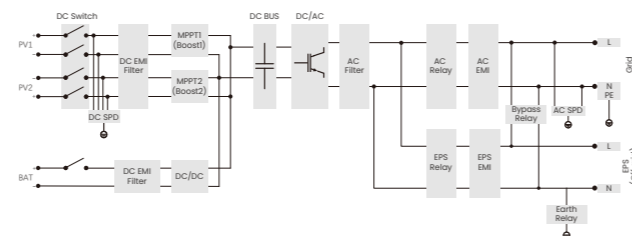

*V3.0 Information may be subject to modify without notice. 650.00009.00

	X1-HYBRID-3.0-D	X1-HYBRID-3.7-D	X1-HYBRID-5.0-D	X1-HYBRID-6.0-D	X1-HYBRID-7.5-D
PV INPUT					
Max. recommended PV array power	6.0 kWp	7.4 kWp	10.0 kWp	12.0 kWp	15.0 kWp
Max. PV input voltage ^①	600 V				
Rated PV input voltage	360 V				
Operation voltage range	70 ~ 550 V				
MPPT voltage range ^②	70 ~ 550 V				
Start-up voltage	90 V				
No. of MPP trackers / Strings per MPP tracker	2 (1 / 1)				
Max. input current per MPPT	16 A / 16 A				
Max. input short circuit current per MPPT	20 A / 20 A				
AC INPUT & OUTPUT (ON-GRID)					
Rated output power	3000 W	3680 W	5000 W (Germany 4600 W, AU 4999 W)	6000 W	7500 W
Max. output apparent power	3300 VA	3680 VA	5500 VA (4600 VA for VDE4105, 4999 VA for AS4777)	6600 VA	7500 VA
Max. output continuous current	14.4 A	16.0 A	23.9 A (Germany 20 A, AU 21.7 A)	28.6 A	32.6 A
Rated AC voltage	1 / N / PE, 220 / 230 / 240 V				
Max. AC input apparent power	6300 VA	7360 VA	9200 VA	9200 VA	9200 VA
Max. AC input current	27.4 A	32.0 A	40.0 A	40.0 A	40.0 A
Nominal AC frequency	50 Hz / 60 Hz				
THDi (rated power)	< 2%				
BATTERY					
Battery type	Lithium / Lead - acid				
Battery voltage range	80 ~ 480 V				
Max. charge / discharge current	30 A				
EPS (OFF-GRID) OUTPUT (WITH BATTERY)					
Rated EPS output voltage, frequency	230 V, 50 Hz / 60 Hz				
Rated EPS output power	3000 VA	3680 VA	5000 VA	6000 VA	7500 VA
Peak EPS output power	6000 VA, 10 s	6000 VA, 10 s	7500 VA, 10 s	9000 VA, 10 s	11250 VA, 10 s
Switchover time	< 10 ms				
EFFICIENCY					
Max. efficiency	97.6%				
European efficiency	97.0%				
ENVIRONMENT LIMIT					
Ingress protection	IP65				
Operation temperature range	-35 ~ 60°C (> 45°C derating)				
Max. operation altitude	3000 m				
Relative humidity	4 ~ 100% RH (condensing)				
GENERAL					
Dimensions (W x H x D)	482 x 417 x 181 mm				
Net weight	24 kg				25 kg
Cooling concept	Natural cooling				Smart air cooling
Communication interfaces	CT / Meter (optional), External control RS485, Dongle interface, DRM, NTC (optional)				
Certification	VDE-AR-N 4105, G99, G98, AS/NZS4777, EN50549, CEI 0-21, C10/11 IEC61727, RD1699, NRS 097-2-1, PEA/MEA, VFR2019, PPDS				
PROTECTION					
Protections	Over / under voltage protection, DC isolation protection, DC reverse-polarity protection				
Active anti-islanding method	Frequency shift				
Surge protection	DC: Type II, AC: Type II				
Arc-fault circuit interrupter (AFCI)	Optional				

① The maximum input voltage is the upper limit of the DC voltage. Any higher input DC voltage would probably damage the inverter
② Input voltage exceeding the MPPT voltage range may trigger inverter protection

Single-phase Residential Hybrid Inverter



X1-VAST

5kW / 6kW / 8kW / 10kW

Smart Management

- V2G/V2H ready for smart home energy integration*
- Smart Schedule, Smart Scene, and 7x24h TOU
- VPP ready with a variety of compatibility(OpenADR, IEEE2030.5, FCAS, API)*
- Wireless meter compatibility
- Support whole-home load without extra devices

High Performance

- 20A DC input per MPPT with 4 trackers
- 200% PV oversizing and high power capacity
- Low PV start-up voltage of 50V

Assured Reliability

- Up to 200% EPS output for 10s
- UPS-level switchover time <10ms
- Type II SPD on AC&DC side
- Optional AFCI protection*

Flexible Adaptability

- Dual battery ports & 2-in-1 function for expansion
- Dedicated multi-device connections for streamlined cabling
- Functional and stylish wiring cover
- Microgrid and generator compatible for resilient off-grid solutions

* Feature to be upgraded in the future

Efficiency Curve

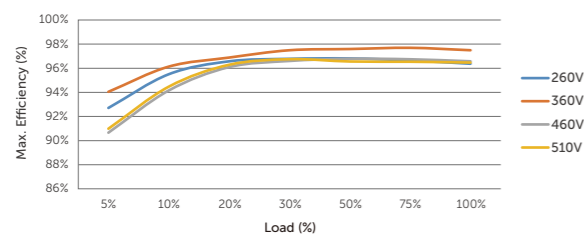

Circuit Diagram

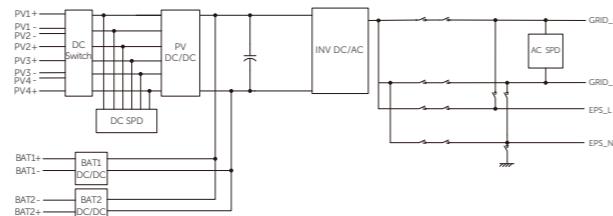

V1.6 Information may be subject to modify without notice. 650.00081.00

	X1-VAST-5K	X1-VAST-6K	X1-VAST-8K	X1-VAST-10K
PV INPUT				
Max. recommended PV array power	10 kWp	12 kWp	16 kWp	20 kWp
Max. PV input voltage ^①	600 V			
Nominal PV input voltage	360 V			
Operating voltage range	40 ~ 560 V			
MPPT voltage range ^②	40 ~ 560 V			
Start-up voltage	50 V			
No. of MPPT trackers / Strings per MPPT tracker	3 / (1 / 1 / 1)		4 / (1 / 1 / 1 / 1)	
Max. input current per MPPT(MPPT1/2/3)	20 A / 20 A / 20 A		20 A / 20 A / 20 A / 20 A	
Max. input short circuit current per MPPT(MPPT1/2/3)	25 A / 25 A / 25 A		25 A / 25 A / 25 A / 25 A	
AC INPUT & OUTPUT(ON-GRID)				
Rated output power	4999 W	6000 W	8000 W	9999 W
Rated output current	21.8 A	26.1 A	34.8 A	43.5 A
Max. output apparent power	4999 VA	6000 VA	8000 VA	9999 VA
Max. output continuous current	21.8 A	26.1 A	34.8 A	43.5 A
Max. AC input apparent power	14500 VA			
Max. AC input current	63 A			
Adjustable Power Factor range	~ 1 (0.8 lagging to 0.8 leading)			
THDi (rated power)	< 2%			
BATTERY				
Battery type	Lithium			
Battery voltage range	80 ~ 480 V			
Max. charge / discharge current ^③	50 A (25 A × 2)			
EPS (OFF-GRID) OUTPUT (WITH BATTERY)				
Rated EPS output voltage, frequency	230 V, 50 Hz / 60 Hz			
Rated EPS output power	5000 VA (4999 VA for Australia)	6000 VA	8000 VA	10000 VA (9999 VA for Australia)
Peak EPS output power	2 times of rated power, 10 s			
Switchover time	< 10 ms			
EFFICIENCY				
Max. efficiency	97.6%			
ENVIRONMENT LIMIT				
Ingress protection	IP66			
Operating ambient temperature range ^④	-35 ~ 60°C			
Max. operating altitude	3000 m			
Relative humidity	4 ~ 100% RH (condensing)			
GENERAL				
Dimensions (W × H × D)	590 × 400 × 180 mm			
Net weight	28 ± 2 kg			
Cooling concept	Nature cooling			
Communication interfaces	CT/Meter (optional), External control RS485, Dongle interface , DRM			
Topology	Transformerless			
Certificates and approvals	EN / IEC62109-1 / -2, AS / NZS 4777, G99, EN 50549-10, BR140, IEC61727, IEC 61683, RD1699, NRS 097-2-1, PEA / MEA, VFR2019			
PROTECTION				
Protections	DC isolation protection, DC reverse-polarity protection, Residual current detection, Over temperature protection			
Active anti-islanding method	Frequency shift			
Surge protection (DC / AC)	DC: Type II, AC: Type II			
Arc-fault circuit interrupter (AFCI)	Optional			

① The maximum input voltage is the upper limit of the DC voltage. Any higher input DC voltage would probably damage the inverter

② Input voltage exceeding the MPPT voltage range may trigger inverter protection

③ If each of the two battery ports is connected to a separate battery, it's 25A per port. If one port is connected to a single battery, it's 30A. If both ports are connected to a single battery using a 2-in-1 splitter cable(sold separately), it's 50A.

④ Derating above +45°C

Three-phase Residential Hybrid Inverter



X3-HYBRID G4

5.0kW / 6.0kW / 8.0kW / 10.0kW / 12.0kW / 15.0kW

X3-HYBRID-5.0-D X3-HYBRID-6.0-D X3-HYBRID-8.0-D X3-HYBRID-10.0-D X3-HYBRID-12.0-D X3-HYBRID-15.0-D

PV INPUT						
Max. recommended PV array power	10 kWp	12 kWp	16 kWp	20 kWp	24 kWp	30 kWp
Max. PV input voltage ^①	1000 V					
Rated PV input voltage	640 V					
MPPT voltage range ^②	180 ~ 950 V					
Start-up voltage	200 V					
No. of MPPT trackers / strings per MPPT tracker	2 (1 / 1)			2 (2 / 1)		
Max. input current per MPPT ^③	16 A / 16 A			28 A / 16 A		
Max. input short circuit current per MPPT	20 A / 20 A			35 A / 20 A		
AC INPUT & OUTPUT (ON-GRID)						
Rated output power	5 kW	6 kW	8 kW	10 kW	12 kW	15 kW
Rated output current	7.2 A	8.7 A	11.6 A	14.5 A	17.5 A	21.8 A
Max. output apparent power	5.5 kVA	6.6 kVA	8.8 kVA	11.0 kVA	13.2 kVA	15.0 kVA
Max. output continuous current	8.1 A	9.7 A	12.9 A	16.1 A	19.3 A	24.1 A
Rated AC voltage	3 / N / PE, 220 / 380 V 3 / N / PE, 230 / 400 V					
Max. AC input apparent power	10 kVA	12 kVA	16 kVA	20 kVA	20 kVA	20 kVA
Max. AC input current	16.1 A	19.3 A	25.8 A	32.0 A	32.0 A	32.0 A
Rated AC frequency	50 Hz / 60 Hz					
Adjustable power factor range	~ 1 (0.8 lagging to 0.8 leading)					
THDi (rated power)	< 3%					
BATTERY						
Battery type	Lithium / Lead-acid					
Battery voltage range ^④	120 ~ 800 V					
Max. charge / discharge current	30 A					
EPS (OFF-GRID) OUTPUT (WITH BATTERY)						
Rated EPS output voltage, frequency	230 V / 400 V, 50 Hz / 60 Hz					
Rated EPS output power	5 kVA	6 kVA	8 kVA	10 kVA	12 kVA	15 kVA
Peak EPS output power	12.0 kVA, 10 s	12.0 kVA, 10 s	18.0 kVA, 10 s	18.0 kVA, 10 s	22.5 kVA, 10 s	22.5 kVA, 10 s
Switchover time	< 10 ms					
EFFICIENCY						
Max. efficiency	98.0%					
European efficiency	97.7%					
ENVIRONMENT LIMIT						
Ingress protection	IP65					
Operation temperature range	-35 ~ 60°C (> 45°C derating)					
Max. operation altitude	3000 m					
Relative humidity	4 ~ 100% RH (condensing)					
Overvoltage category	Mains: III, Battery: II, PV: II					
GENERAL						
Dimensions (W x H x D)	503 x 503 x 199 mm					
Net weight	30 ± 1 kg					
Cooling concept	Natural cooling			Smart air cooling		
Communication interfaces	CT / Meter (optional), External control RS485, Pocket WiFi (Optional: Pocket LAN/4G), DRM, NTC (optional)					
Power consumption (night)	< 40 W for standby, < 5 W for idle					
Topology	Non-isolated					
Certifications	EN/IEC62109-1/-2, VDE4105, G99, G98, AS4777, EN50549, CEI 0-21, IEC61727, PEA/MEA, NRS-097-2-1, RD1699, TOR					
PROTECTION						
Protections	DC reverse-polarity protection, DC isolation protection, Residual current detection, AC overcurrent protection, AC short-circuit protection, Over / under voltage protection, Grid monitoring, DC injection monitoring, Back feed current monitoring, Over temperature protection					
Active anti-islanding method	Frequency shift					
Surge protection	DC: Type II, AC: Type II					
Arc-fault circuit interrupter (AFCI)	Optional					

Smart Management

- VPP ready, ancillary service in power market
- Global MPP scan for optimal energy harvest
- Smart loads management(e.g. heat pump, smart EV charger)
- Intelligent ToU-driven energy management

Assured Reliability

- Up to 200% EPS overload output for 10 seconds*
- UPS-level switchover time <10ms
- IP65 Ingress protection
- Type II SPD on AC&DC side

High Performance

- 200% PV oversizing and up to 110% AC output
- Up to 97.5% efficiency in charging and discharging
- Up to 200% PV input
- Three-phase unbalanced output: Max. 5kW per phase

Flexible Adaptability

- Lithium & Lead-acid battery compatible
- On-grid and off-grid parallel function, up to 150kW
- Max. 28A input per MPPT, optimized for high-power solar panels.
- Quick configuration via U-disk

*Overload capabilities vary by model. Please refer to the specification page for detailed information

Efficiency Curve

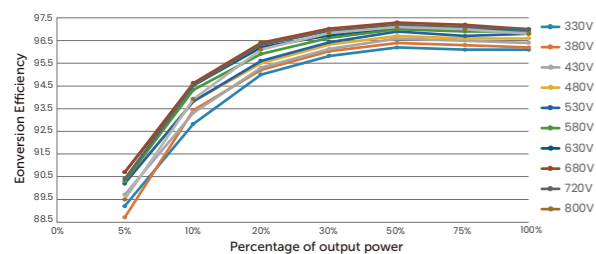

Circuit Diagram

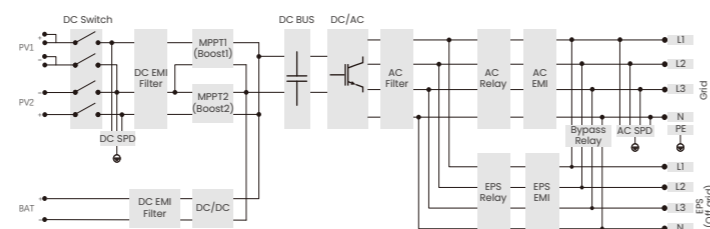

① The maximum input voltage is the upper limit of the DC voltage. Any higher input DC voltage would probably damage the inverter
 ② Input voltage exceeding the MPPT voltage range may trigger inverter protection
 ③ When PV1 is connected to 2 strings, the maximum input current is 28A; when PV1 is connected to 1 string, the maximum input current is 20A
 ④ Compatible with a minimum of 3 units of HS25/HS36 batteries, but if the total voltage of the 3 batteries is less than 127V and there is no PV input, the system will not be able to startup

Three-phase Residential Hybrid Inverter



X3-HYB G4 PRO

4kW / 5kW / 6kW / 8kW
10kW / 12kW / 15kW

Smart Management

- V2X ready for smart home energy integration
- Smart Schedule, Smart Scene, and 7*24h ToU
- Wireless meter compatibility
- VPP ready with a variety of compatibility(OpenADR, IEEE2030.5, FCAS, API)*

High Performance

- 20A DC input per MPPT with 3 trackers
- 200% PV oversizing and up to 110% AC output
- Ultra-wide MPPT range of 110-950V

Assured Reliability

- Up to 200% EPS output for 10s
- UPS-level switchover time <10ms
- Optional Rapid Shutdown function for enhanced safety
- Type II SPD on AC&DC side
- Optional AFCI protection*

Flexible Adaptability

- Dual battery ports & 2-in-1 function for expansion
- Additional ports for simplified wiring and installation
- Functional and stylish wiring cover
- Microgrid and generator modes for versatile operations

* Feature to be upgraded in the future

Efficiency Curve (15kW)

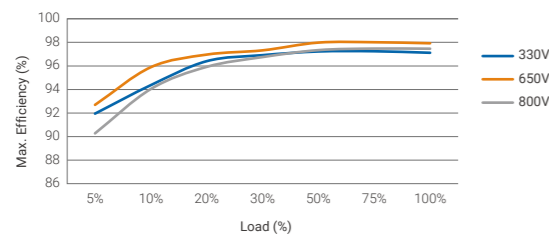

Circuit Diagram

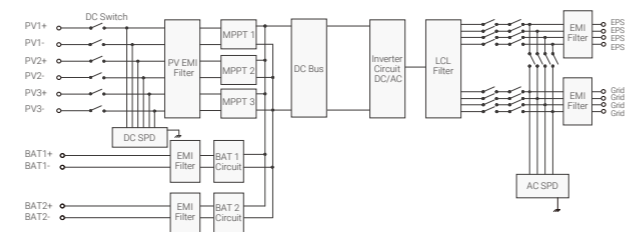

*V2.6 Information may be subject to modify without notice. 650.00082.00

	X3-HYB-4.0-P	X3-HYB-5.0-P	X3-HYB-6.0-P	X3-HYB-8.0-P	X3-HYB-10.0-P	X3-HYB-12.0-P	X3-HYB-15.0-P
PV INPUT							
Max. recommended PV array power	8 kWp	10 kWp	12 kWp	16 kWp	20 kWp	24 kWp	30 kWp
Max. PV input voltage ^①	1000 V						
Rated PV input voltage	650 V						
Operation voltage range	110 ~ 950 V						
MPPT voltage range ^②	110 ~ 950 V						
Start-up voltage	120 V						
No. of MPPT trackers / strings per MPPT tracker	2 (1 / 1)			3 (1 / 1 / 1)			
Max. input current per MPPT	20 A / 20 A			20 A / 20 A / 20 A			
Max. input short circuit current per MPPT	25 A / 25 A			25 A / 25 A / 25 A			
AC INPUT & OUTPUT (ON-GRID)							
Rated output power	4000 W	5000 W (AS 4777 4999 W)	6000 W	8000 W	10000 W (AS 4777 9999 W)	12000 W	15000 W (AS 4777 14999 W)
Rated output current	5.8 A	7.2 A	8.7 A	11.6 A	14.5 A	17.5 A	21.8 A
Max. output apparent power	4400 VA	5500 VA (AS 4777 4999 VA)	6600 VA	8800 VA	11000 VA (AS 4777 9999 VA)	13200 VA	16500 VA (AS 4777 14999 VA)
Max. output continuous current	6.7 A	8.4 A	10 A	13.4 A	16.7 A	20.0 A	25.0 A
Rated AC voltage	3 / N / PE, 220 / 380 V 3 / N / PE, 230 / 400 V						
Max. AC input apparent power	8.4 kVA	10.5 kVA	12.6 kVA	16.8 kVA	21.0 kVA		
Max. AC input current	12.2 A	15.2 A	18.2 A	24.3 A	30.4 A		
Rated AC frequency	50 Hz / 60 Hz						
AC frequency range ^③	50 ± 5 Hz / 60 ± 5 Hz						
Adjustable power factor range	~ 1 (0.8 lagging to 0.8 leading)						
THDi (rated power)	< 3%						
BATTERY							
Battery type	Lithium						
Battery voltage range ^④	120 ~ 800 V						
Max. charge / discharge current ^⑤	50 A (25 A × 2)						
EPS (OFF-GRID) OUTPUT (WITH BATTERY)							
Rated EPS output voltage, frequency	230 V / 400 V, 50 Hz / 60 Hz						
Rated EPS output power	4 kVA	5 kVA	6 kVA	8 kVA	10 kVA	12 kVA	15 kVA
Peak EPS output power	2 times of rated power, 10 s						
Switchover time	< 10 ms						
EFFICIENCY							
Max. efficiency	98.0%						
European efficiency	97.7%						
ENVIRONMENT LIMIT							
Ingress protection	IP66						
Operation temperature range	-35 ~ 60°C (> 45°C derating)						
Max. operation altitude	3000 m						
Relative humidity	0 ~ 100% RH (condensing)						
Overvoltage category	Mains: III, Battery: II, PV: II						
GENERAL							
Dimensions (W × H × D)	560 × 503 × 210 mm						
Net weight	38 kg						
Cooling concept	Natural cooling				Smart air cooling		
Communication interfaces	COM1 (Parallel 1, Parallel 2, BMS 1, BMS 2, RS485, Meter / CT); COM2 (DI/DO, EVC, XHUB, DRM, V2X, Heatpump)						
Power consumption (night)	< 40 W for standby, < 5 W for idle						
Topology	Non-isolated						
Certifications	IEC62109-1 / IEC62109-2, VDE 0126-1-1 A1:2012, VDE-AR-N 4105, G98, G99, AS4777, EN50549, CEI 0-21						
PROTECTION							
Protection	Over / under voltage protection, DC isolation protection, DC reverse-polarity protection, Grid monitoring, DC injection monitoring, Back feed current monitoring, Residual current detection, Over temperature protection, AC overcurrent protection, AC short-circuit protection						
Active anti-islanding method	Frequency shift						
Surge protection	DC: Type II, AC: Type II						
Arc-fault circuit interrupter (AFCI)	Optional						

①The maximum input voltage is the upper limit of the DC voltage. Any higher input DC voltage would probably damage the inverter ②Input voltage exceeding the MPPT voltage range may trigger inverter protection ③The AC frequency range may vary from different country codes ④Compatible with a minimum of 3 units of HS25/HS36 batteries, but if the total voltage of the 3 batteries is less than 127V and there is no PV input, the system will not be able to startup ⑤If only one port is connected to a single battery, it's 30A. If both ports are connected to a single battery using a 2-in-1 splitter cable (sold separately), it's 50A

Three-phase C&I Hybrid Inverter



X3-ULTRA

15kW / 19.9kW / 20kW
25kW / 30kW

Smart Management

- Single unit UPS-level switchover time <10ms
- Built-in shadow tracking
- Smart loads management(e.g. heat pump, smart EV charger)
- Loads respond time within 0.3 s
- VPP ready with a variety of compatibility (OpenADR, IEEE2030.5, FCAS, API)*

High Performance

- 200% PV oversizing and up to 110% AC output
- 200% EPS overload for 10s
- Max. 60A charging / discharging current
- Low start-up voltage for more power generation

Assured Reliability

- IP66 Ingress protection
- Type II SPD on AC&DC side
- Optional AFCI protection**

Flexible Adaptability

- Max. 10pcs parallel for on-grid and off-grid
- Microgrid and generator function for versatile operations
- Max. 36A PV input per MPPT, optimized for high-power solar panel

*Some features coming soon
**Standard in Brazil

Efficiency Curve

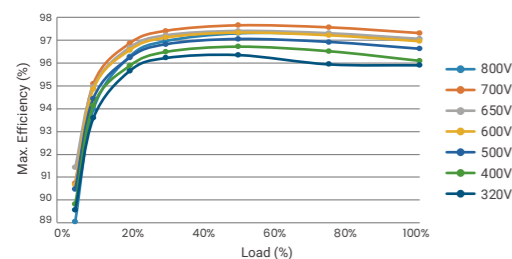

Circuit Diagram

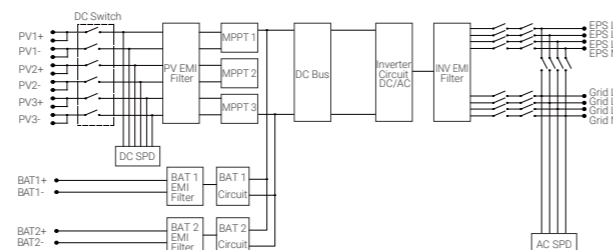

*V2.2 Information may be subject to modify without notice. 650.00038.00

	X3-ULT-15K	X3-ULT-15KP	X3-ULT-19.9K	X3-ULT-20K	X3-ULT-20KP	X3-ULT-25K	X3-ULT-30K
PV INPUT							
Max. recommended PV array power	30000 Wp		40000 Wp		50000 Wp	60000 Wp	
Max. PV input voltage ^①	1000 V						
Rated PV input voltage	600 V						
Operating voltage range	120 - 950 V						
Start-up voltage	200 V						
No. of MPPT trackers / Strings per MPPT tracker	2 (2 / 2)	3 (2 / 2 / 2)	2 (2 / 2)		3 (2 / 2 / 2)		
Max. input current per MPPT	36 / 36 A	36 / 36 / 36 A	36 / 36 A		36 / 36 / 36 A		
Max. input short circuit current per MPPT	45 / 45 A	45 / 45 / 45 A	45 / 45 A		45 / 45 / 45 A		
AC INPUT & OUTPUT (ON-GRID)							
Rated output apparent power	15000 VA (AS4777 14999 VA)	19999 VA	20000VA		25000 VA (VDE4105 24900 VA)	30000 VA (AS4777 29999 VA, VDE4105 29900 VA)	
Rated output current	21.8 A@230 V	29.0 A@230 V	29.0 A@230 V		36.3 A@230 V	43.5 A@230 V	
Max. output apparent power	16500 VA (AS4777 14999 VA)	19999 VA	22000 VA		27500 VA (VDE4105 24900 VA)	30000 VA (AS4777 29999 VA, VDE4105 29900 VA)	
Max. output continuous current	24.0 A@230 V (AS4777 21.8 A@230 V)	29.0 A@230 V	31.9 A@230 V		39.9 A@230 V (VDE4105 36.3 A@230 V)	43.5 A@230 V	
Rated AC voltage	3W / N / PE, 220 / 380 V 3W / N / PE, 230 / 400 V						
Max. AC input apparent power	15000 VA	19999 VA	20000 VA		25000 VA	30000 VA	
Max. AC input current	50.0 A						
Rated grid Frequency	50 / 60 Hz						
AC frequency range	50 ± 5 Hz / 60 ± 5 Hz						
Adjustable power factor range	1 (- 0.8 ~ 0.8)						
BATTERY							
Battery type	Lithium						
Battery voltage range ^{②③}	120- 800 V						
Max. charge / discharge current	60 A (30 × 2)						
EPS OUTPUT(WITH BATTERY)							
Rated EPS apparent power	15000VA	19999 VA	20000 VA		25000 VA	30000 VA	
Peak EPS output power	2 time of rated power, 10 s						
Rated EPS output voltage, frequency	230 / 400 V, 50 / 60 Hz						
Switchover time	< 10 ms						
EFFICIENCY							
Max. efficiency	98.0%						
European Efficiency	97.7%						
ENVIRONMENT LIMIT							
Ingress protection	IP66						
Operating temperature range	-35 ~ 60°C (> 45°C derating)						
Max. operating altitude	3000 m						
Relative humidity	0 ~ 100% RH (condensing)						
Overvoltage category	Mains: III, Battery: II, PV: II						
GENERAL							
Dimensions(W x H x D)	696 × 526 × 240 mm						
Net weight	46 kg	47.5 kg	46kg	47.5 kg	48.5kg		
Cooling concept	Smart air cooling						
Communication interfaces	RS485, CAN, DRM, DI/DO						
Power consumption (night)	< 5 W						
Topology	Non-isolated						
Cetifications	VDE4105, G99, AS4777, EN50549, CEI 0-21, IEC61727, PEA/MEA, NRS-097-2-1, RD1699, TOR						
PROTECTION							
Protections	Over / under voltage protection, DC isolation protection, DC reverse-polarity protection, Grid monitoring, DC injection monitoring, Back feed current monitoring, Residual current detection, Over temperature protection, AC overcurrent protection, AC short-circuit protection, Active anti-islanding method						
Surge protection	DC: Type II, AC: Type II						
Arc-fault circuit interrupter (AFCI)	Optional						

① The maximum input voltage is the upper limit of the DC voltage. Any higher input DC voltage would probably damage inverter
 ② Compatible with a minimum of 3 units of HS series batteries, but if the total voltage of the 3 batteries is less than 127V and there is no PV input, the system will not able to startup
 ③ When the voltage is below 180V, the inverter will limit the battery current to less than 20A

High-voltage Battery System



T-BAT H 3.0 V2

T-BAT H 3.0 V2



	T-BAT H 3.0 T-BAT H 3.0 V2	T-BAT H 6.0 T-BAT H 6.0 V2	T-BAT H 9.0 T-BAT H 9.0 V2	T-BAT H 12.0 T-BAT H 12.0 V2
Rated voltage	102.4 V	204.8 V	307.2 V	409.6 V
Operation voltage range	90 ~ 116 V	180 ~ 232 V	270 ~ 348 V	360 ~ 464 V
Total energy	3.1 kWh	6.1 kWh	9.2 kWh	12.3 kWh
Usable energy ^①	2.8 kWh	5.5 kWh	8.3 kWh	11.0 kWh
Rated capacity	30 Ah			
Rated power	2.5 kW	5.1 kW	7.6 kW	10.2 kW
Max. power	3.1 kW	6.1 kW	9.2 kW	12.3 kW
Recommend charge / discharge current	25 A			
Max. charge / discharge current ^②	30 A			
Battery roundtrip efficiency	95%			
Cycle life [90% DOD]	> 6000 cycles			
Warranty	10 years			
Charge temperature	-30 ~ +50°C (with heating function) 0 ~ +50°C (without heating function)			
Discharge temperature	-30 ~ +50°C (with heating function) -20 ~ +50°C (without heating function)			
Storage temperature	-20 ~ 30°C (12 months) 30 ~ 50°C (6 months)			
Relative humidity	4 ~ 100% RH (condensing)			
Max. operation altitude	3000 m			
Ingress protection	IP65			
Battery to Inverter	RS485 / CAN2.0			
Battery to battery / BMS	CAN2.0			
Master control capacity indicator	4 LED (25%, 50%, 75%, 100%)			
Master control LED indicator (working mode)	1 LED			
System switch (on / off)	Button × 1 + Breaker × 1			
Certifications	CE, IEC62619, IEC62040, UKCA, VDE2510, RoHS			
UN number	UN3480			
Hazardous materials classification	Class 9			
UN transportation testing requirements	UN 38.3			
Dimensions (W × H × D)	MC0600: 482.5 × 173.5 × 153 mm HV10230: 482.5 × 471.5 × 153 mm			
Net weight	MC0600: 7.5 kg + HV10230: 34.5 kg	MC0600: 7.5 kg + 2 × HV10230: 69 kg	MC0600: 7.5 kg + 3 × HV10230: 103.5 kg	MC0600: 7.5 kg + 4 × HV10230: 138 kg

Smart Management

- Remote fault diagnosis, upgrade and maintenance
- Unique battery heating tech for low-temperature operation

Assured Reliability

- LFP battery cell & high-performance processors
- Safety Certifications: CE, UN38.3, etc.
- IP65 ingress protection

High Performance

- Cycle life > 6000 cycles
- High capacity utilization
- Efficient energy transfer

Flexible Adaptability

- Compatible with BMS-Parallel Box-II G2 , up to 2 towers of batteries
- Stackable modules, supporting floor mounting

*V2.6.Information may be subject to modify without notice. 650.00011.00

① Test conditions: 90% DOD, 0.2C charge & discharge @25 °C
② Max. charge / discharge current may be variant with different inverter models

High-voltage Battery System



T-BAT-SYS-HV-S2.5

5.12 kWh ~ 33.28 kWh

Aerosol Fire Extinguish Module

Smart Management

- Remote fault diagnosis, upgrade and maintenance
- Unique battery heating tech for low-temperature operation

High Performance

- 5.1-33.2 kWh wide capacity range
- Max. 50A charging / discharging current
- Cycle life > 6000 cycles







Assured Reliability





- LFP battery cell & high-performance processors
- IP65 Ingress protection
- Soft start to protect from a sudden surge
- Aerosol fire suppression for precise protection

Flexible Adaptability

- Supports battery expansion
- Stackable modules, plug and play design
- With TCBox-70, supports up to three battery towers; with battery expansion cables, supports up to two battery towers^①

^① Selection should be based on the inverter's actual compatibility

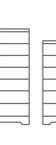
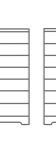
	T-BAT HS5.0	T-BAT HS7.5	T-BAT HS10.0	T-BAT HS12.5	T-BAT HS15.0	T-BAT HS17.5
Number of modules	 2	 3	 4	 5	 6	 7
GENERAL INFORMATION						
Nominal voltage	102.4 d.c. V	153.6 d.c. V	204.8 d.c. V	256.0 d.c. V	307.2 d.c. V	358.4 d.c. V
Operating voltage range	90 - 116 d.c. V	135 - 174 d.c. V	180 - 232 d.c. V	225 - 290 d.c. V	270 - 349 d.c. V	315 - 406 d.c. V
Nominal energy	5.1 kWh	7.6 kWh	10.2 kWh	12.8 kWh	15.3 kWh	17.9 kWh
Usable energy (90% DOD) ^①	4.6 kWh	6.9 kWh	9.2 kWh	11.5 kWh	13.8 kWh	16.1 kWh
Rated charge / discharge power	3.1 kW	4.6 kW	6.1 kW	7.7 kW	9.2 kW	10.8 kW
Max. charge / discharge power	5.1 kW	7.6 kW	10.2 kW	12.8 kW	15.3 kW	17.9 kW
Dimensions (W × H × D)	510 × 522 × 365 mm	510 × 659.5 × 365 mm	510 × 797 × 365 mm	510 × 934.5 × 365 mm	510 × 1072 × 365 mm	510 × 1209.5 × 365 mm

	T-BAT HS20.0	T-BAT HS22.5	T-BAT HS25.0	T-BAT HS27.5	T-BAT HS30.0	T-BAT HS32.5
Number of modules	 8	 9	 10	 11	 12	 13
GENERAL INFORMATION						
Nominal voltage	409.6 d.c. V	460.8 d.c. V	512.0 d.c. V	563.2 d.c. V	614.4 d.c. V	665.6 d.c. V
Operating voltage range	360 - 465 d.c. V	405 - 522 d.c. V	450 - 580 d.c. V	495 - 636 d.c. V	540 - 695 d.c. V	585 - 750 d.c. V
Nominal energy	20.4 kWh	23.0 kWh	25.6 kWh	28.1 kWh	30.7 kWh	33.2 kWh
Usable energy (90% DOD) ^①	18.4 kWh	20.7 kWh	23.0 kWh	25.3 kWh	27.6 kWh	30.0 kWh
Rated charge / discharge power	12.3 kW	13.8 kW	15.4 kW	16.9 kW	18.4 kW	20.0 kW
Max. charge / discharge power	20.4 kW	23.0 kW	25.6 kW	28.1 kW	30.7 kW	33.2 kW
Dimensions (W × H × D)	510 × 1347 × 365 mm	510 × 1484.5 × 365 mm	510 × 1622 × 365 mm	510 × 1072 × 365 mm + 510 × 934.5 × 365 mm	510 × 1072 × 365 mm + 510 × 1072 × 365 mm	510 × 1209.5 × 365 mm + 510 × 1072 × 365 mm

GENERAL INFORMATION	
Depth of discharge(DOD)	90%
Recommend charge / discharge current	30 A
Max. charge / discharge current ^②	50 A
Cycle life (90% DOD) ^③	> 6000 Cycles
ENVIRONMENTAL REQUIREMENTS	
Charge temperature	-30 - +53°C (with heating function) 0 - +53°C (without heating function)
Discharge temperature	-30 - +53°C (with heating function) -20 - +53°C (without heating function)
Storage temperature	-20 - +30°C (12 months) +30 - +50°C (6 months)
Relative humidity	4 - 100% RH (condensing)
Max. operating altitude	3000 m
Ingress protection	IP65
BMS	
Model	TBMS - MCS0800
Dimensions (W × H × D)	510 × 157 × 365 mm
Net weight	13 (±0.5) kg
BATTERY MODEL	
Battery model	TP-HS25
Battery type	LFP
Module capacity	2.5 kWh
Dimensions (W × H × D)	510 × 152 × 365 mm
Net weight	30 (±1) kg
SERIES BOX	
Dimensions (W × H × D)	510 × 157 × 365 mm
Net weight	10 (±0.5) kg
COMMUNICATION STANDARD	
Communication interfaces	CAN2.0 / RS485
Certifications	IEC62619, IEC60730, IEC62040, CE, UN38.3, UL9540A ^④

^① Test conditions: 90% DOD, 0.2C charge & discharge @+25°C

^② Current is affected by the number of batteries connected in parallel as well as temperature and SOC

^③ Test conditions: 25±2°C, 0.5C charge & discharge, 70% EOL

^④ UL9540A certification coming soon

High-voltage Battery System

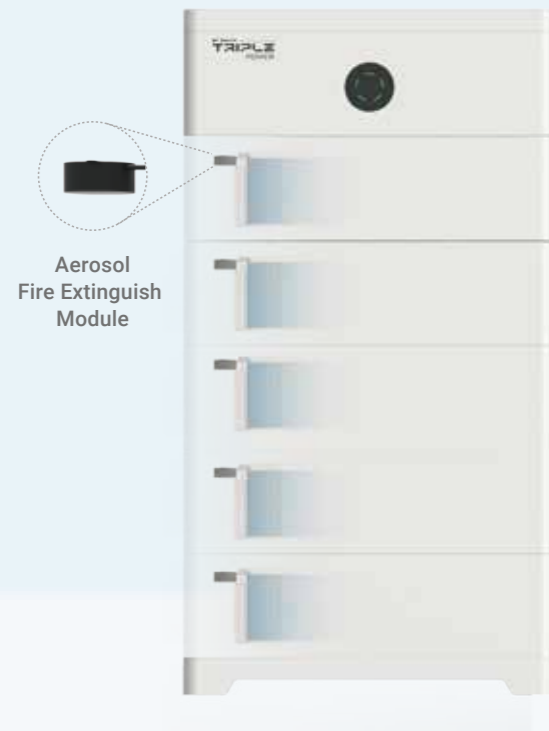

T-BAT-SYS-HV-S3.6

7.37 kWh ~ 47.92 kWh

Smart Management

- Remote fault diagnosis, upgrade and maintenance
- Unique battery heating tech for low-temperature operation

High Performance

- 7.3 - 47.9 kWh wide capacity range
- Max. 50A charging / discharging current
- Cycle life > 6000 cycles

Assured Reliability

- LFP battery cell & high-performance processors
- IP65 Ingress protection
- Soft start to protect from a sudden surge
- Aerosol fire suppression for precise protection

Flexible Adaptability

- Supports battery expansion
- Stackable modules, plug and play design
- With TCBox-70, supports up to three battery towers; with battery expansion cables, supports up to two battery towers^①

^① Selection should be based on the inverter's actual compatibility

*V1.9. Information may be subject to modify without notice. 650.00032.00

	T-BAT HS7.2	T-BAT HS10.8	T-BAT HS14.4	T-BAT HS18.0	T-BAT HS21.6	T-BAT HS25.2
Number of modules	2	3	4	5	6	7
GENERAL INFORMATION						
Nominal voltage	102.4 d.c. V	153.6 d.c. V	204.8 d.c. V	256.0 d.c. V	307.2 d.c. V	358.4 d.c. V
Operating voltage range	90 - 116 d.c. V	135 - 174 d.c. V	180 - 232 d.c. V	225 - 290 d.c. V	270 - 349 d.c. V	315 - 406 d.c. V
Nominal energy	7.3 kWh	11.0 kWh	14.7 kWh	18.4 kWh	22.1 kWh	25.8 kWh
Usable energy (90% DOD) ^①	6.6 kWh	10.0 kWh	13.3 kWh	16.6 kWh	19.9 kWh	23.2 kWh
Rated charge / discharge power	3.5 kW	5.3 kW	7.1 kW	8.9 kW	10.7 kW	12.5 kW
Max. charge / discharge power	5.1 kW	7.6 kW	10.2 kW	12.8 kW	15.3 kW	17.9 kW
Dimensions (W x H x D)	510 x 522 x 365 mm	510 x 659.5 x 365 mm	510 x 797 x 365 mm	510 x 934.5 x 365 mm	510 x 1072 x 365 mm	510 x 1209.5 x 365 mm

	T-BAT HS20.0	T-BAT HS22.5	T-BAT HS25.0	T-BAT HS27.5	T-BAT HS30.0	T-BAT HS32.5
Number of modules	8	9	10	11	12	13
GENERAL INFORMATION						
Nominal voltage	409.6 d.c. V	460.8 d.c. V	512.0 d.c. V	563.2 d.c. V	614.4 d.c. V	665.6 d.c. V
Operating voltage range	360 - 465 d.c. V	405 - 522 d.c. V	450 - 580 d.c. V	495 - 636 d.c. V	540 - 695 d.c. V	585 - 750 d.c. V
Nominal energy	29.4 kWh	33.1 kWh	36.8 kWh	40.5 kWh	44.2 kWh	47.9 kWh
Usable energy (90% DOD) ^①	26.5 kWh	29.9 kWh	33.2 kWh	36.5 kWh	39.8 kWh	43.1 kWh
Rated charge / discharge power	14.3 kW	16.1 kW	17.9 kW	19.7 kW	21.5 kW	23.3 kW
Max. charge / discharge power	20.4 kW	23.0 kW	25.6 kW	28.1 kW	30.7 kW	33.2 kW
Dimensions (W x H x D)	510 x 1347 x 365 mm	510 x 1484.5 x 365 mm	510 x 1622 x 365 mm	510 x 1072 x 365 mm + 510 x 934.5 x 365 mm	510 x 1072 x 365 mm + 510 x 1072 x 365 mm	510 x 1209.5 x 365 mm + 510 x 1072 x 365 mm

GENERAL INFORMATION	
Depth of discharge(DOD)	90%
Recommend charge / discharge current	35 A
Max. charge / discharge current ^②	50 A
Cycle life (90% DOD) ^③	> 6000 Cycles

ENVIRONMENTAL REQUIREMENTS	
Charge temperature	-30 - +53°C (with heating function) 0 - +53°C (without heating function)
Discharge temperature	-30 - +53°C (with heating function) -20 - +53°C (without heating function)
Storage temperature	-20 - +30°C (12 months) +30 - +50°C (6 months)
Relative humidity	4 - 100% RH (condensing)
Max. operating altitude	3000 m
Ingress protection	IP65

BMS	
Model	TBMS - MCS0800
Dimensions (W x H x D)	510 x 157 x 365 mm
Net weight	13 (±0.5) kg

BATTERY MODEL	
Battery model	TP-HS36
Battery type	LFP
Module capacity	3.6 kWh
Dimensions (W x H x D)	510 x 152 x 365 mm
Net weight	34 (±1) kg

SERIES BOX	
Dimensions (W x H x D)	510 x 157 x 365 mm
Net weight	10 (±0.5) kg

COMMUNICATION STANDARD	
Communication interfaces	CAN2.0 / RS485

CERTIFICATIONS	
Certifications	IEC62619, IEC60730, IEC62040, CE, UN38.3, UL9540A ^④

^① Test conditions: 90% DOD, 0.2C charge & discharge @+25°C
^② Current is affected by the number of batteries connected in parallel as well as temperature and SOC
^③ Test conditions: 25±2°C, 0.5C charge & discharge, 70% EOL
^④ UL9540A certification coming soon

High-Voltage Battery System

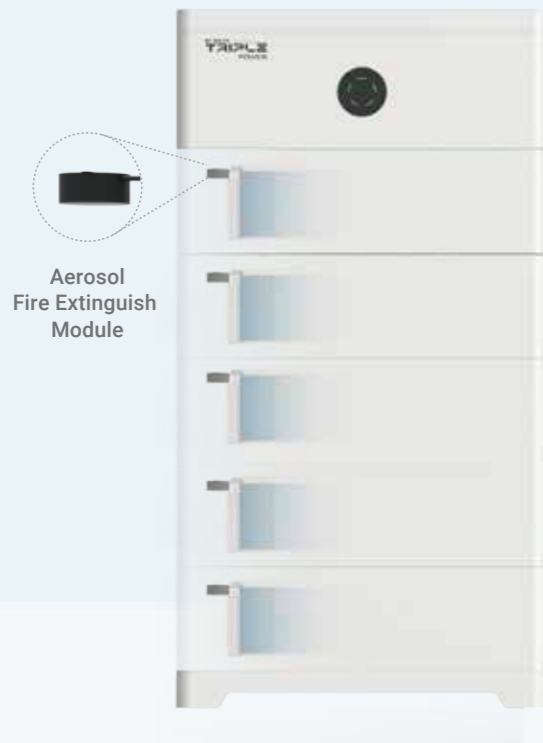

TSYS-HS51

10.2kWh ~ 66.5kWh

Aerosol Fire Extinguish Module

Smart Management

- Remote fault diagnosis, upgrade and maintenance
- Unique battery heating tech and wide temperature tolerance
- Optional parallel connection using a two-in-one cable for easy capacity expansion and extend battery lifespan
- Maximum 10% expansion of effective power over the entire life cycle to increase cycle life (optimizer version)^①
- 3-hour rapid equalization (optimizer version)^②

High Performance

- 10.2 - 66.5 kWh wide capacity range
- Max. 70A charging / discharging current
- Cycle life > 6000 cycles

Assured Reliability

- IP66 ingress protection
- LFP battery cell & high-performance processors
- Aerosol fire suppression for precise protection

Flexible Adaptability

- Compatible with TCBox-70, up to 3 towers of batteries^③
- Compact and stackable for easy installation
- Supporting direct battery expansion
- Supporting mixed use of new and old batteries, supports rapid capacity expansion, plug and play, no energy loss (optimizer version)

^① Lab conditions

^② Lab data, quick equalization of 20% power difference in 3 hours

^③ Coming soon

*V1.7. Information may be subject to modify without notice. 650.00071.00

	T-HS10.2	T-HS15.3	T-HS20.4	T-HS25.6	T-HS30.7	T-HS35.8
GENERAL INFORMATION						
Nominal voltage	102.4 V	153.6 V	204.8 V	256.0 V	307.2 V	358.4 V
Operating voltage range	85 ~ 116 V	128 ~ 174 V	170 ~ 232 V	212 ~ 289 V	255 ~ 347 V	297 ~ 405 V
Nominal energy	10.2 kWh	15.3 kWh	20.4 kWh	25.6 kWh	30.7 kWh	35.8 kWh
Depth of discharge(DOD)	90%					
Usable energy(90% DOD) ^①	9.1 kWh	13.7 kWh	18.3 kWh	23.0 kWh	27.6 kWh	32.2 kWh
Rated charge/ discharge power	6.1 kW	9.2 kW	12.3 kW	15.4 kW	18.4 kW	21.5 kW
Max. charge/ discharge power	7.2 kW	10.8 kW	14.3 kW	17.9 kW	21.5 kW	25.1 kW
Recommend charge / discharge current	60 A					
Max. charge / discharge current ^②	70 A					
Cycle life (90% DOD) ^③	> 6000 cycles					
Warranty	10 years					

	T-HS40.9	T-HS46.0	T-HS51.2	T-HS56.3	T-HS61.4	T-HS66.5
GENERAL INFORMATION						
Nominal voltage	409.6 V	460.8 V	512.0 V	563.2 V	614.4 V	665.6 V
Operating voltage range	340 ~ 463 V	382 ~ 520 V	424 ~ 578 V	467 ~ 636 V	509 ~ 694 V	552 ~ 750 V
Nominal energy	40.9 kWh	46.0 kWh	51.2 kWh	56.3 kWh	61.4 kWh	66.5 kWh
Depth of discharge(DOD)	90%					
Usable energy(90% DOD) ^①	36.8 kWh	41.4 kWh	46.0 kWh	50.6 kWh	55.2 kWh	59.8 kWh
Rated charge/ discharge power	24.6 kW	27.6 kW	30.7 kW	33.8 kW	36.9 kW	39.9 kW
Max. charge/ discharge power	28.7 kW	32.3 kW	35.8 kW	39.4 kW	43.0 kW	46.6 kW
Recommend charge / discharge current	60 A					
Max. charge / discharge current ^②	70 A					
Cycle life (90% DOD) ^③	> 6000 cycles					
Warranty	10 years					

ENVIRONMENTAL REQUIREMENTS	
Charge temperature	-30 ~ 53°C (with heating function) 0 ~ 53°C (without heating function)
Discharge temperature	-30 ~ 53°C (with heating function) -20 ~ 53°C (without heating function)
Cooling concept	Natural cooling
Storage temperature	-20°C ~ 30°C (12 months) 30°C ~ 50°C (6 months)
Relative humidity	4 ~ 100% RH (non-condensing)
Max. operating altitude	3000 m
Installation type	Stackable
Ingress protection	IP66
Environment	Outdoor / indoor

BMS	
Model	TBMS-S51-8 / TBMS-S51-80
Dimensions (W x H x D)	600 x 225 x 376 mm
Net weight	18.5 kg

BATTERY MODEL	
Battery model	TB-HS51 / TB-HS510
Battery type	LFP
Scalability	2 ~ 13
Module capacity	5.1 kWh
Dimensions (WxHxD)	600 x 168 x 376 mm
Net weight	46 kg / 47.1 kg (with optimizer)

COMMUNICATION	
Communication interfaces	CAN2.0 / RS485

STANDARD	
Transport testing requirement	UN38.3
Certifications	IEC62619, IEC62040, EN62477, VDE 2510

ACCESSORIES	
Series box	
Dimensions (WxHxD):	600 x 376 x 225 mm
Net weight	14.6 kg
Base	
Dimensions (WxHxD):	600 x 376 x 60 mm
Net weight	4.7 kg

^① Test conditions: 90% DOD, 0.2C charge & discharge @ 25°C

^② Current is affected by the number of batteries connected in parallel as well as temperature and SOC

^③ Test conditions: 25±2°C, 0.5C charge & discharge, 70%EOL

High-voltage Battery System



T-BAT H 5.8
(Master)



T-BAT H 5.8 V2
(Master)



HV11550 / HV11550 V2
(Slave)

High Performance

- 90% Depth of Discharge (DOD)
- Cycle life > 6000 times

Assured Reliability

- LFP battery cell & high-performance processors
- IP65 protection degree
- No toxic heavy metals or caustic materials

Smart Management

- Remote fault diagnosis, upgrade and maintenance

Flexible Adaptability

- Floor or wall mounting optional

T-BAT H 5.8
T-BAT H 5.8 V2 **T-BAT H 11.5**
T-BAT H 11.5 V2 **T-BAT H 17.3**
T-BAT H 17.3 V2 **T-BAT H 23**
T-BAT H 23 V2

NOMINAL CHARACTER				
Nominal voltage	115.2 V	230.4 V	345.6 V	460.8 V
Operating voltage	100 ~ 131 V	200 ~ 262 V	300 ~ 393 V	400 ~ 524 V
Battery type	LFP			
Total capacity	5.8 kWh	11.5 kWh	17.3 kWh	23.0 kWh
Usable capacity ^①	5.1 kWh	10.4 kWh	15.5 kWh	20.7 kWh
Battery roundtrip efficiency	95%			
Standard power	2.8 kW	5.7 kW	8.6 kW	11.5 kW
Max power	4.0 kW	8.0 kW	12.0 kW	16.1 kW
Recommend charge / discharge current	25 A			
Max charge / discharge current	35 A			
Short circuit current	760 A			
Cycle life	> 6000 cycles			
Warranty	10 years			
ENVIRONMENT REQUIREMENT				
Operating temperature	Charge: 0 ~ 55°C / Discharge: -10 ~ 55°C			
Storage temperature	-20 ~ 30°C (12 months) , 30 ~ 55°C (6 months)			
Relative humidity	4 ~ 100% RH (condensing)			
Altitude	< 2000 m			
Ingress protection	IP65			
COMMUNICATION				
System to inverter	CAN2.0			
Battery to battery / BMS	RS485			
Data collection port / FW update	CAN2.0			
Master control working mode indicator	1 LED			
Master control capacity indicator	4 LED (25%, 50%, 75%, 100%)			
Battery module LED	2 LED			
Reset	Button			
Switch ON / OFF	Button × 1 + breaker × 1			
STANDARD				
Safety (V1)	CE, IEC 62619, UKCA, VDE2510, JIS-C 8715, UL1973, FCC, REACH			
Safety (V2)	CE, IEC 62040, IEC 62619, UKCA, VDE2510, RoHS, REACH			
UN number	UN3480			
Hazardous materials classification	Class 9			
Transport testing requirement	UN38.3			
GENERAL				
Dimensions (L × W × H)	474 × 193 × 708 mm	474 × 193 × 708 mm + 474 × 193 × 647 mm	474 × 193 × 708 mm + (474 × 193 × 647 mm) × 2	474 × 193 × 708 mm + (474 × 193 × 647 mm) × 3
Weight	72.2 kg	72.2 kg + 68.5 kg	72.2 kg + 68.5 kg × 2	72.2 kg + 68.5 kg × 3

① Test conditions: 90% DOD, 0.2C charger & discharger @+25°C

* X3 Hybrid inverter can connect 2-4pcs of T58 batteries (1pc of T58 master, and rest 1-3pcs of T58 slave)

* X1 Hybrid inverter can connect 1-3pcs of T58 batteries (1pc of T58 master, without T58 slave, or with 1-2pcs of T58 slave)

* With BMS Parallel Box-II, the maximum battery quantity connected on each inverter varies, please kindly check datasheet of BMS Parallel Box-II

* Maximum Charge/Discharge Current may be variant with different inverter models

* Maximum Charge/Discharge Current may be variant at different temperature and SOC

* HV11550 V1 and HV11550 V2 share the same appearance

High-voltage Battery System



T-BAT H 5.8(H) V3

HV11550(H) V3



Flexible Battery Heating

5.8kWh ~ 34.6kWh

High Performance

- Max expandable to 6 units with 34.6kWh capacity for single cluster: cover more customer usage scenarios*
- 95% Depth of Discharge (DOD): Delivers more usable energy over its lifetime
- Cycle life> 6000 cycles: Ultra-long lifespan, ensuring consistent performance and long-term reliability
- Flexible Heating: The T58-V3 features flexible two-level battery heating, desianed to meet diverse user needs foroptimal performance

Smart Management

- Remote fault diagnosis, upgrade and maintenance: Rapid issue identification

Assured Reliability

- Aerosol fire suppression for precise protection
- IP66 Ingress protection
- No toxic heavy metals or caustic materials
- LFP battery cell & high-performance processors

Flexible Adaptability

- Floor or wall mounting optional: fits multiple installation scenarios

*Inverters with two battery ports: Max expandable to 6 units with 69.1kWh capacity

	T-BAT H 5.8 V3/ T-BAT H 5.8H V3	T-BAT H 11.5 V3/ T-BAT H 11.5H V3	T-BAT H 17.3 V3/ T-BAT H 17.3H V3	T-BAT H 23.0 V3/ T-BAT H 23.0H V3	T-BAT H 28.8 V3/ T-BAT H 28.8H V3	T-BAT H 34.6 V3/ T-BAT H 34.6H V3
--	------------------------------------	--------------------------------------	--------------------------------------	--------------------------------------	--------------------------------------	--------------------------------------

GENERAL INFORMATION						
Nominal voltage	115.2 V	230.4 V	345.6 V	460.8 V	576 V	691.2 V
Operating voltage range	100 - 130 V	200 - 260 V	300 - 390 V	400 - 520 V	500 - 650 V	600 - 750 V
Nominal energy	5.8 kWh	11.5 kWh	17.3 kWh	23.0 kWh	28.8 kWh	34.6 kWh
Depth of discharge(DOD)	95%					
Usable energy(90% DOD)①	5.5 kWh	10.9 kWh	16.4 kWh	21.9 kWh	27.4 kWh	32.9 kWh
Rated charge/ discharge power	2.9 kW	5.8 kW	8.6 kW	11.5 kW	14.4 kW	17.3 kW
Max. charge/ discharge power	4 kW	8.1 kW	12.1 kW	16.1 kW	20.2 kW	24.2 kW
Peak output current/power	50 A, @20 s					
Recommend charge / discharge current	25 A					
Max. charge / discharge current②	35 A					
Cycle life (90% DOD)③	> 6000 Cycles					
Warranty	10 Years					

ENVLRONMENTAL REQLREMENTS	
Charge temperature	0 ~ 55°C (Off heating function) -30 ~ 55°C (On heating function) ④
Discharge temperature	-20 ~ 55°C (Off heating function) -30 ~ 55°C (On heating function) ④
Cooling concept	Natural
Storage temperature	-20~30°C (12 months)
Relative humidity	4 ~ 100% (Condensing)
Max. operating altitude	2000 m
Installation type	Wall mounting / Floor mounting
Ingress protection	IP66
Environment	Outdoor / indoor

BATTERY MODULE (BMS+PACK)	
Model	T-BAT H 5.8(H) V3
Dimensions (W x H x D)	474 x 715 x 150 mm
Net weight	61.5 (±1) kg

BATTERY MODEL	
Battery model	HV11550 (H) V3
Battery type	LFP
Scalability	1~5
Module capacity	5.8 kWh
Dimensions (WxHxD)	474 x 715 x 150 mm
Net weight	59.5 (±1) kg

COMMUNICATION	
Communication interfaces	CAN 2.0 + RS485

STANDARD	
Hazardous materials classification	Class 9
Transport testing requirement	UN38.3
Protection class	Class I
Certifications	IEC62619 / IEC63056 / IEC60730 / IEC62040 / IEC61000-1&-3 / EN62477 / VDE2510

① Test conditions: 95% DOD, 0.2C charge & discharge @+25°C
 ② Current is affected by the number of batteries connected in parallel as well as temperature and SOC
 ③ Test conditions: 25°C±2°C,0.5C charge & discharge,70%EOL
 ④ Discharge: In case of battery cell's temperature range of -20°C~10°C and 45°C~55°C, the discharge current will be reduced; Charge: In case of battery cell's temperature range of 0°C~25°C and 45°C~55°C, the charge current will be reduced. Product charge or discharge power depends on the actual temperature of battery pack.
 ⑤ The battery can only be discharged and can not be charged when the battery cell's temperature range is between -20°C and 0°C"

All-in-one Residential ESS



X-ESS G4

3-7.5 kW / 5-15 kW
3~12kWh

Smart Management

- Real-time monitoring via SolaXCloud
- Global MPP scan for optimal energy harvest
- Smart loads management (e.g. heat pump, smart EV charger)
- Intelligent ToU-driven energy management

High Performance

- 200% PV oversizing and up to 110% AC output
- Max. 16A DC single string input current
- Max. 30A charging / discharging current

Assured Reliability

- IP65 protection degree
- Support three-phase unbalance output

Flexible Adaptability

- All-in-one, plug-and-play design
- Quick installation by one person in 30 minutes
- Compatible with EV charger and heat pump

THE OPTIMAL SOLUTION FOR ENERGY STORAGE

The SolaX X-ESS G4 is an all-in-one smart energy storage system that combines an inverter, battery, and Matebox, streamlining installation for maximum ease and efficiency. The modular design offers flexible configurations, allowing the system to scale according to energy needs.

● X-Hybrid G4

Available in single-phase (3–7.5 kW) and three-phase (5–15 kW) options, the X-Hybrid G4 system supports parallel operation of up to 10 inverters, delivering a maximum power output of 150 kW. It includes integrated fault management and emergency power output, with a rapid switching time of less than 10 ms for uninterrupted power.

● Matebox

The Matebox comes with pre-installed components and cabling, significantly reducing installation time. For enhanced functionality, an advanced X3-Matebox version is available, providing whole-house backup power capabilities.

● Battery T30

The T30 battery is scalable from 3 kWh to 12 kWh, adapting to different energy storage requirements. With built-in temperature control, it operates reliably within a wide temperature range of -30°C to 50°C, ensuring optimal performance in various environmental conditions.

● SolaXCloud

Real-time monitoring and analytics with SolaXCloud: providing insights to optimize energy consumption and enhance overall system performance.



Battery Scalability

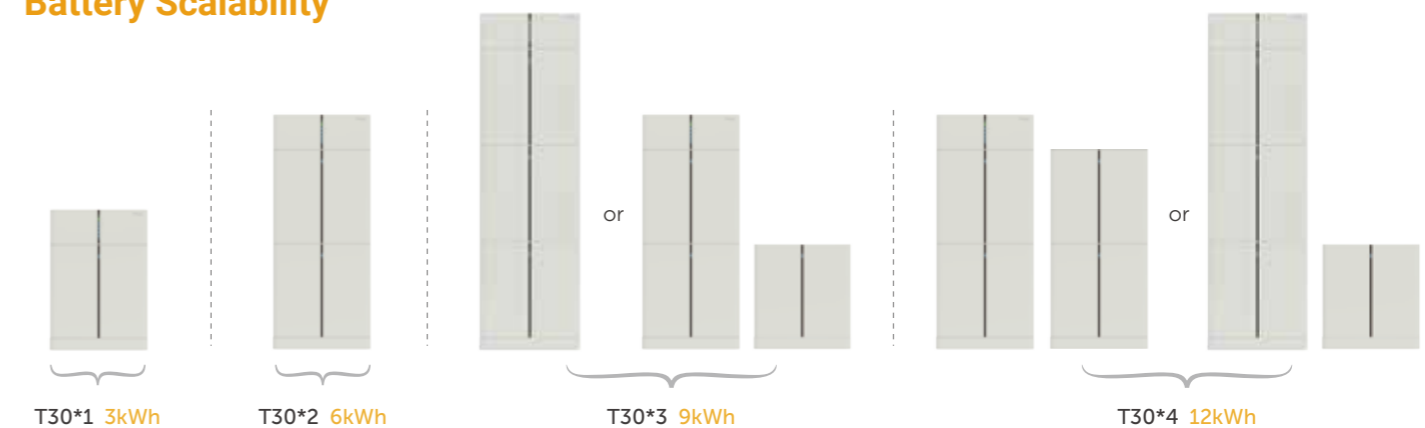

All-in-one Residential ESS



X3-IES

4kW / 5kW / 6kW / 8kW / 10kW /
12kW / 15kW

Efficiency Curve

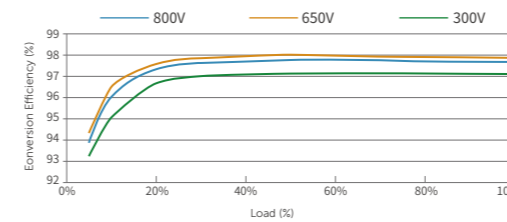

Circuit Diagram

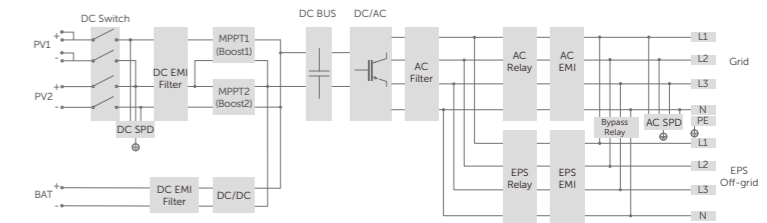

SYSTEM OVERVIEW

System schematic



Smart Management

- AI ready, forecasting solar generation and home consumption for smart energy management strategy control*
- VPP ready with a variety of compatibility(OpenADR, IEEE2030.5, FCAS, API)**
- Smart loads management (e.g., heat pump, smart EV charger)
- Micro-grid support for real-time grid/off-grid balancing
- Wireless meter compatibility
- Global MPP scan for optimal energy harvest

Assured Reliability

- IP66 ingress protection
- Type II SPD on AC&DC side
- AFCI protection (optional)
- Up to 200% EPS output for 10s
- UPS-level switchover time <10ms

High Performance

- Max. 50A charge/discharge current
- 200% oversizing and 200% PV input power
- Low start-up voltage for longer operation
- Cycle life > 6000 cycles

Flexible Adaptability

- All-in-one, plug-and-play design
- Max. 20A DC input current for high power solar panel

*Additional X1-HUB required
**Feature to be upgraded in the future

Rated power	4 / 5 / 6 / 8 / 10 / 12 / 15 kW				
Number of batteries	2	3	4	5	6
Rated energy ^①	10.2 kWh	15.3 kWh	20.4 kWh	25.6 kWh	30.7 kWh
Usable energy ^②	9.2 kWh	13.8 kWh	18.4 kWh	23.0 kWh	27.6 kWh
Max. power ^③	10.2 kW	15.0 kW	15.0 kW	15.0 kW	15.0 kW
Ingress protection	IP66				
Operation temperature range	-30 ~ 53°C				
Relative humidity	5 ~ 95% (no condensation)				
Max. operation altitude	3000 m				
Net weight ^④	144.2 kg	191.2 kg	144.2 kg / 100.5 kg	144.2 kg / 147.5 kg	191.2 kg / 147.5 kg
Dimensions (W x H x D)	730 x 1281 x 209.5 mm	730 x 1599 x 209.5 mm	730 x 1281 x 209.5 mm / 730 x 809 x 150 mm	730 x 1281 x 209.5 mm / 730 x 1127 x 150 mm	730 x 1599 x 209.5 mm / 730 x 1127 x 150 mm
Display	LCD				
Cooling concept	Natural cooling				
Topology	Non-isolated				
Communication interface	RS485, Pocket-X, USB, CAN, DO, DI				

① Test conditions: 25°C, 100% depth of discharge (DoD), 0.2C charge & discharge
 ② System usable energy may vary with inverter different setting
 ③ The max.charge/discharge power must not exceed the rated output power (the table takes the maximum power inverter as an example)
 ④ Different inverter models have different weights. The heaviest one is taken as an example

	X3-IES-4K	X3-IES-5K	X3-IES-6K	X3-IES-8K	X3-IES-10K	X3-IES-12K	X3-IES-15K
PV INPUT							
Max. recommended PV array power	8 kWp	10 kWp	12 kWp	16 kWp	20 kWp	24 kWp	30 kWp
Max. PV input voltage ^①	1000 V						
Rated PV input voltage	600 V						
Operation voltage range	90 ~ 950 V						
MPPT voltage range ^②	110 ~ 950 V						
Start-up voltage	140 V						
No. of MPP trackers / Strings per MPP tracker	2 / (1 / 1)			2 / (2 / 1)			
Max. input current per MPPT	20 A / 20 A			32 A / 20 A			
Max. input short circuit current per MPPT	25 A / 25 A			40 A / 25 A			

AC INPUT & OUTPUT (ON-GRID)							
Rated output power	4000 W	5000 W	6000 W	8000 W	10000 W (AS4777 9999)	12000 W	15000 W
Rated output current	5.8 A	7.3 A	8.7 A	11.6 A	14.5 A	17.4 A	21.8 A
Max. output apparent power	4000 VA	5500 VA	6600 VA	8800 VA	10000 VA (AS4777 9999)	13200 VA	16500 VA
Max. output continuous current	5.8 A	8.0 A	9.6 A	12.8 A	14.5 A	19.2 A	24.0 A
Rated AC voltage	3 / N / PE, 220 / 380 V 3 / N / PE, 230 / 400 V						
Max. AC input apparent power	10 kVA	10 kVA	12 kVA	16 kVA	20 kVA	20 kVA	20 kVA
Max. AC input current	16.1 A	16.1 A	19.3 A	25.8 A	32.0 A	32.0 A	32.0 A
Rated AC frequency	50 Hz / 60 Hz						
AC frequency range ^③	50 ± 5 Hz / 60 ± 5 Hz						
Adjustable power factor range	~ 1 (0.8 lagging to 0.8 leading)						
THDi (rated power)	< 3%						

BATTERY							
Operation voltage range	160 ~ 800 V						
Communication interfaces	CAN / RS485						
BMS module	TBMS-MCS0800E						
Battery module	TP-HS50E						
Composition	TBMS-MCS0800E + TP-HS50E x n + Base Dimensions + Series Box (Required for two columns)						
Battery type	Li-ion (LFP)						
Rated capacity / rated capacity ^④	5.1 kWh / 50 Ah						
Usable energy ^⑤	4.6 kWh						
Rated power	3 kW						
Max. power	5.1 kW						
Max. charge / discharge current ^⑥	50 A						
Cycle life	> 6000 cycles						
Warranty	10 years						
Certifications	CE, RCM, TUV (IEC62619), RoHS, REACH						
TBMS-MCS0800E dimensions (W x H x D) / net weight	730 x 165 x 150 mm / 9.3 kg						
TP-HS50E dimensions (W x H x D) / net weight	730 x 318 x 150 mm / 47 kg						
Base dimensions (W x H x D) / net weight	730 x 75 x 150 mm / 3.9 kg						
Series box dimensions (W x H x D) / net weight	167 x 91.5 x 121 mm / 1.3 kg						

	X3-IES-4K	X3-IES-5K	X3-IES-6K	X3-IES-8K	X3-IES-10K	X3-IES-12K	X3-IES-15K
EPS (OFF-GRID) OUTPUT (WITH BATTERY)							
Rated EPS output voltage, frequency	230 V / 400 V, 50 Hz / 60 Hz						
Rated EPS output power	4 kVA	5 kVA	6 kVA	8 kVA	10 kVA	12 kVA	15 kVA
Peak EPS output power	2 times of rated power, 10s						
Switchover time	< 10 ms						
EFFICIENCY							
Max. efficiency	98.0%						
European efficiency	97.7%						
ENVIRONMENT LIMIT							
Ingress protection	IP66						
Operation temperature range	-35 ~ 60°C (> 45°C derating)						
Max. Operation altitude	3000 m						
Relative humidity	0 ~ 100% RH (condensing)						
Overvoltage category	Mains: III, Battery: II, PV: II						
GENERAL							
Dimensions (W x H x D)	717 x 405 x 209.5 mm						
Net weight	37 kg						
Cooling concept	Natural cooling						
Communication interfaces	RS485, Pocket-X, CAN, DO, DI						
Power consumption (night)	< 40 W for hot standby, < 5 W for cold standby						
Topology	Non-isolated						
Certifications	IEC62109-1 / IEC62109-2, VDE 0126-1-1 A1:2012 / VDE-AR-N 4105 / G98 / G99 / AS4777 / EN50549 / CEI 0-21						
PROTECTION							
Protections	Over voltage protection, DC reverse-polarity protection, Residual current detection, Over temperature protection, DC isolation protection, Grid monitoring, DC injection monitoring, Back feed current monitoring						
Active anti-islanding method	Frequency shift						
Surge protection	DC: Type II, AC: Type II						
Arc-fault circuit interrupter (AFCI)	Optional						

① The maximum input voltage is the upper limit of the DC voltage. Any higher input DC voltage would probably damage the inverter

② Input voltage exceeding the MPPT voltage range may trigger inverter protection

③ The AC frequency range may vary from different country codes

④ Test conditions: 25°C, 100% depth of discharge (DoD), 0.2C charge & discharge

⑤ System usable energy may vary with inverter different settings

⑥ Discharge: In case of the battery cell's temperature range of -20°C~10°C and 45°C~53 °C, the discharge current will be reduced; Charge: In case of the battery cell's temperature range of 0°C~25°C and 45°C~53°C, the charge current will be reduced. Product charge or discharge power depends on the actual temperature of the battery pack

All-in-one Residential ESS



X3-IES-P

4kW / 5kW / 6kW / 8kW /
10kW / 12kW / 15kW

Efficiency Curve

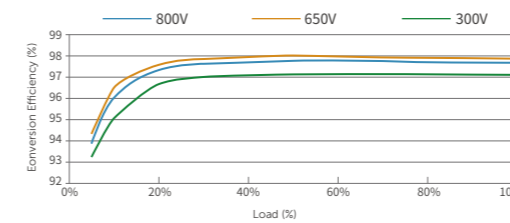

Circuit Diagram

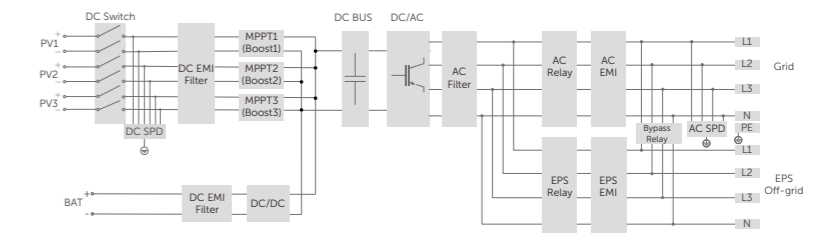

SYSTEM OVERVIEW

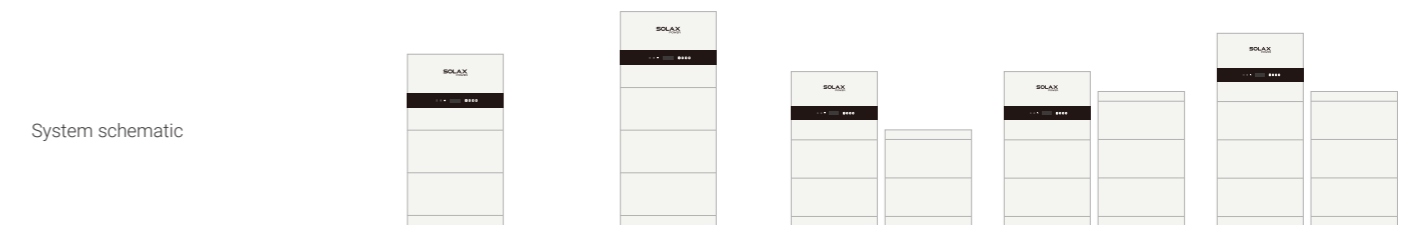

	4 / 5 / 6 / 8 / 10 / 12 / 15 kW				
Rated output power	4 / 5 / 6 / 8 / 10 / 12 / 15 kW				
Number of batteries	2	3	4	5	6
Nominal capacity ^①	10.2 kWh	15.3 kWh	20.4 kWh	25.6 kWh	30.7 kWh
Usable energy ^②	9.2 kWh	13.8 kWh	18.4 kWh	23.0 kWh	27.6 kWh
Max. charge / discharge power ^③	10.2 kW	15.0 kW	15.0 kW	15.0 kW	15.0 kW
Degree of protection	IP66				
Operating temperature range	-30 ~ 53°C				
Allowable relative humidity range	5 ~ 95% (No condensation)				
Max. operating altitude	3000 m				
Net weight ^④	147.2 kg	194.2 kg	147.2 / 103.5 kg	147.2 / 150.5 kg	194.2 / 150.5 kg
Dimension (W x H x D)	730 x 1281 x 209.5 mm	730 x 1599 x 209.5 mm	730 x 1281 x 209.5 mm / 730 x 809 x 150 mm	730 x 1281 x 209.5 mm / 730 x 1127 x 150 mm	730 x 1599 x 209.5 mm / 730 x 1127 x 150 mm
Display	LCD				
Cooling concept	Natural cooling				
Topology	Non-isolated				
Communication	RS485, Pocket-X, USB, CAN, DO, DI				

① Test conditions: 25°C, 100% depth of discharge (DoD), 0.2C charge & discharge
 ② System usable energy may vary with inverter different setting
 ③ The max.charge/discharge power must not exceed the rated output power (the table takes the maximum power inverter as an example)
 ④ Different inverter models have different weights. The heaviest one is taken as an example

Smart Management

- AI ready, forecasting solar generation and home consumption for smart energy management strategy control*
- VPP ready with a variety of compatibility (OpenADR, IEEE2030.5, FCAS, API)**
- Micro-grid support for real-time balance in grid/off-grid
- Wireless meter solution
- Smart Schedule, Smart Scene, and 7*24h TOU
- Global MPP scan for optimal energy harvest

Assured Reliability

- IP66 protection degree
- Type II SPD on AC&DC side
- AFCI protection (optional)**
- Unique battery heating tech and wide temperature tolerance
- Up to 200% EPS output for 10s
- UPS-level switchover time <10ms

High Performance

- Max. 3 MPPTs for versatile application scenarios
- 200% oversizing and 200% PV input power
- Max. 20A PV input per MPPT
- Low startup voltage for higher energy harvest

Flexible Adaptability

- All-in-one, plug-and-play design
- Support smart scene functions (e.g., heat pump, EV charger)
- Versatile installation for varied needs

*Additional Datahub 1000 required
 **Feature to be upgraded in the future

	X3-IES-4K-P	X3-IES-5K-P	X3-IES-6K-P	X3-IES-8K-P	X3-IES-10K-P	X3-IES-12K-P	X3-IES-15K-P
PV INPUT							
Max. recommended PV array power	8 kWp	10 kWp	12 kWp	16 kWp	20 kWp	24 kWp	30 kWp
Max. PV input voltage ^①	1000 V						
Nominal PV input voltage	600 V						
Operating voltage range	90 ~ 950 V						
MPPT voltage range ^②	110 ~ 950 V						
Start-up voltage	140 V						
No. of MPP trackers / Strings per MPP tracker	2 / (1 / 1)			3 / (1 / 1 / 1)			
Max. input current per MPPT (MPPT1//2/3)	20 A / 20 A			20 A / 20 A / 20 A			
Max. input short circuit current per MPPT (MPPT1/2/3)	25 A / 25 A			25 A / 25 A / 25 A			
AC INPUT & OUTPUT (ON-GRID)							
Rated output power	4kW	5kW (AS4777 4999)	6kW	8 kW	10 kW (AS4777 9999)	12 kW	15 kW (AS14999)
Rated output current	5.8 A	7.3 A	8.7 A	11.6 A	14.5 A	17.4 A	21.8 A
Max. output apparent power	4000 VA	5500 VA (AS4777 4999)	6600 VA	8800 VA	10000 VA (AS4777 9999)	13200 VA	16500 VA (AS14999)
Max. output continuous current	6.1 A	8.4 A	10 A	13.4 A	15.2 A	20.0 A	25.0 A
Nominal AC voltage	3 / N / PE, 220 / 380 V 3 / N / PE, 230 / 400 V						
Max. AC input apparent power	10kVA	10KVA	12kV	16 kVA	20 kVA	20 kVA	20 kVA
Max. AC input current	16.1 A	16.1 A	19.3 A	25.8 A	32.0 A	32.0 A	32.0 A
Nominal AC frequency	50 Hz / 60 Hz						
AC frequency range ^③	50 ± 5 Hz / 60 ± 5 Hz						
Adjustable power factor range	~ 1 (0.8 lagging to 0.8 leading)						
THDi (rated power)	< 3%						
BATTERY							
Battery voltage range	160 ~ 800 V						
Communication interfaces	CAN / RS485						
BMS module	TBMS-MCS0800E						
Battery module	TP-HS50E						
Composition	TBMS-MCS0800E + TP-HS50E x n + Base Dimensions + Series Box (Required for two columns)						
Battery type	Li-ion (LFP)						
Nominal capacity / Nominal capacity ^④	5.1 kWh / 50 Ah						
Usable energy ^⑤	4.6 kWh						
Standard power	3 kW						
Max power	5.1 kW						
Max. charge / discharge current ^⑥	50 A						
Cycle life	> 6000 cycles						
Warranty	10 years						
Safety	CE, RCM, TUV (IEC62619), RoHS, REACH						
TBMS-MCS0800E dimensions (W x H x D) / Weight	730 x 165 x 150 mm / 9.3 kg						
TP-HS50E dimensions (W x H x D) / Weight	730 x 318 x 150 mm / 47 kg						
Base dimensions (W x H x D) / Weight	730 x 75 x 150 mm / 3.9 kg						
Series box dimensions (W x H x D) / Weight	167 x 91.5 x 121 mm / 1.3 kg						

	X3-IES-4K-P	X3-IES-5K-P	X3-IES-6K-P	X3-IES-8K-P	X3-IES-10K-P	X3-IES-12K-P	X3-IES-15K-P
EPS (OFF-GRID) OUTPUT (WITH BATTERY)							
Rated EPS output voltage, frequency	230 V / 400 V, 50 Hz / 60 Hz						
Rated EPS output power	4 kVA	5 kVA	6 kVA	8 kVA	10 kVA	12 kVA	15 kVA
Peak EPS output power	2 times of rated power, 10 s						
Switchover time	< 10 ms						
EFFICIENCY							
Max. efficiency	98.0%						
European efficiency	97.7%						
ENVIRONMENT LIMIT							
Ingress protection	IP66						
Operating ambient temperature range ^⑦	-35 ~ 60°C						
Max. operating altitude	3000 m						
Relative humidity	0 ~ 100% RH (condensing)						
Overvoltage Category	Mains: III, Battery: II, PV: II						
GENERAL							
Dimensions (W x H x D)	717 x 405 x 209.5 mm						
Net weight	40 kg						
Cooling concept	Nature cooling						
Communication interfaces	RS485, Pocket-X, CAN + RS485, DO, DI						
Power consumption (night)	< 40 W for hot standby, < 5 W for cold standby						
Topology	Non-isolated						
Certificates and approvals	IIEC62109-1 / IEC62109-2, VDE 0126-1-1 A1:2012 / VDE-AR-N 4105 / G98 / G99 / AS4777 / EN50549 / CEI 0-21						
AC auxiliary power supply (APS)	Built-in						
PROTECTION							
Protections	Over voltage protection, DC reverse-polarity protection, Residual current detection, Over temperature protection, DC isolation protection, Grid monitoring, DC injection monitoring, Back feed current						
Active anti-islanding method	Frequency shift						
Surge protection (DC / AC)	DC: Type II, AC: Type II						
Arc-fault circuit interrupter (AFCI)	Optional						

① The maximum input voltage is the upper limit of the DC voltage. Any higher input DC voltage would probably damage the inverter

② Input voltage exceeding the MPPT voltage range may trigger inverter protection

③ The AC frequency range may vary from different country codes

④ Test conditions: 25°C, 100% depth of discharge (DoD), 0.2C charge & discharge

⑤ System usable energy may vary with inverter different settings

⑥ Discharge: In case of the battery cell's temperature range of -20°C~10°C and 45°C~53°C, the discharge current will be reduced; Charge: In case of the battery cell's temperature range of 0°C~25°C and 45°C~53°C, the charge current will be reduced. Product charge or discharge power depends on the actual temperature of the battery pack

⑦ Derating above +45°C



SMART SOLAR, STORAGE & ENERGY SOLUTIONS
Accessory for Energy Storage

Accessories

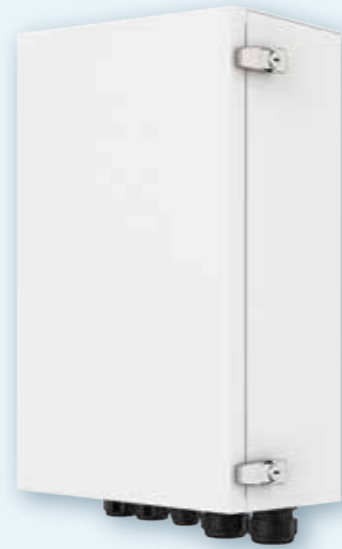

X1-Matebox G2

We get rid of complicated wiring work by laying all the wires in the Matebox. All you need to do is just to connect all the cables which are already well-sorted in the Matebox. This helps to save time and money.

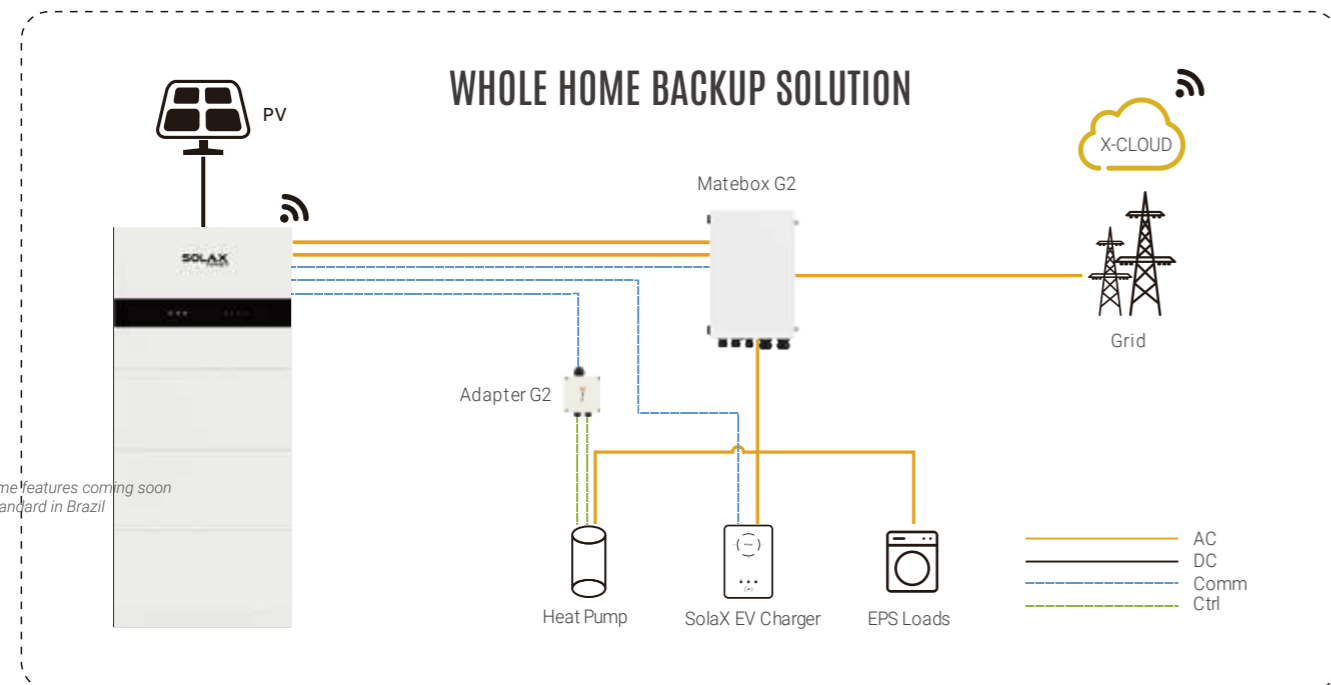

*V1.3. Information may be subject to modify without notice. 650.00053.00

X1-Matebox G2

ON-GRID (INVERTER)	
Rated voltage, frequency	220 / 230 / 240 Vac, 50 / 60 Hz
Max. apparent on-grid input/output power	8000 VA
Max. on-grid current	40 A
OFF-GRID (INVERTER)	
Rated voltage, frequency	230 Vac, 50 / 60 Hz
Max. apparent off-grid input/output power	8000 VA
Max. off-grid current	40 A
GRID (UTILITY)	
Rated grid voltage, frequency	220 / 230 / 240 Vac, 50 / 60 Hz
Max. current	63 A (100 A for England)
LOAD	
Rated voltage, frequency	220 / 230 / 240 Vac, 50 / 60 Hz
Max. current	63 A (100 A for England)
ENVIRONMENT LIMIT	
Ingress protection	IP65
Protection class	Class I
Operation temperature range	-25 ~ 60°C (> 45°C derating)
Storage temperature	-40 ~ 70°C
Relative humidity	0 ~ 100% RH (condensing)
Max. operation altitude	3000 m
Overvoltage category	III (AC)
OTHER	
Cooling concept	Natural cooling
DIMENSION AND WEIGHT	
Dimensions(WxHxD)	549 x 360 x 192 mm
Net weight	11 kg

Accessories

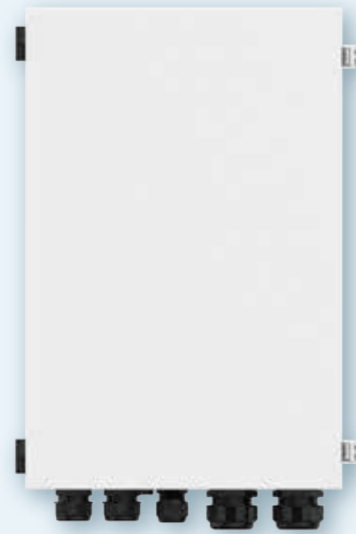

X3-Matebox G2

We get rid of complicated wiring work by laying all the wires in the Matebox. All you need to do is just to connect all the cables which are already well-sorted in the Matebox. This helps to save time and money.

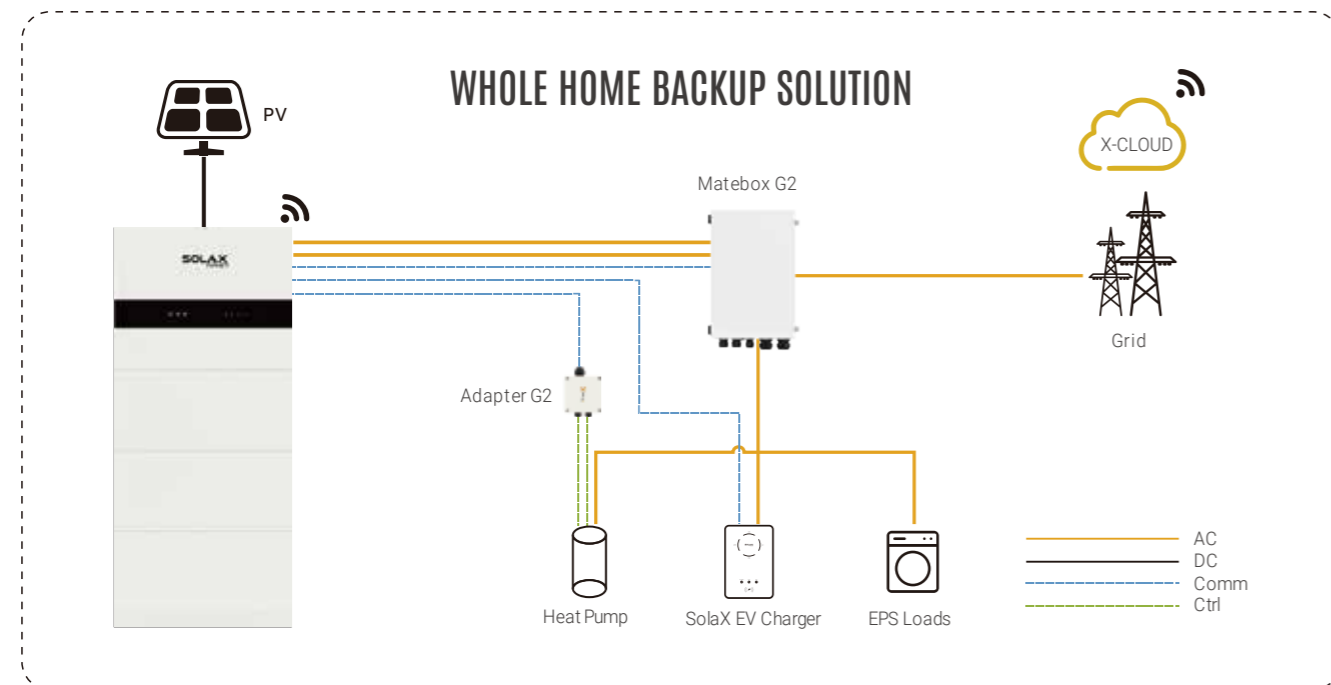

*V1.3. Information may be subject to modify without notice. 650.00054.00

X3-Matebox G2

ON-GRID (INVERTER)	
Rated voltage, frequency	380 / 400 / 415 Vac, 50 / 60 Hz
Max. apparent on-grid input/output power	16500 VA
Max. on-grid current	32 A
OFF-GRID (INVERTER)	
Rated voltage, frequency	380 / 400 / 415 Vac, 50 / 60 Hz
Max. apparent off-grid input/output power	15000 VA
Max. off-grid current	25 A
GRID (UTILITY)	
Rated grid voltage, frequency	380 / 400 / 415 Vac, 50 / 60 Hz
Max. current	63 A
LOAD	
Rated voltage, frequency	380 / 400 / 415 Vac, 50 / 60 Hz
Max. current	63 A
ENVIRONMENT LIMIT	
Ingress protection	IP65
Protection class	Class I
Operation temperature range	-25 ~ 60°C (> 45°C derating)
Storage temperature	-40~+70°C
Relative humidity	0~100% RH (condensing)
Max. operation altitude	3000 m
Overvoltage category	III(AC)
OTHER	
Cooling concept	Natural cooling
DIMENSION AND WEIGHT	
Dimensions(WxHxD)	549 × 360 × 192 mm
Net weight	13.5 kg

Accessories



BMS-Parallel Box-II G2

BMS-PARALLEL BOX-II G2

ENVIRONMENT REQUIREMENT				
Input / Output voltage range	70 ~ 550 V			
Standard power	11.5 kW			
Maximum power	16.1 kW			
Operating charge / discharge temperature range ^①	T-BAT-H 3.0: -30 ~ 55°C (with heating function) -10 ~ 55°C (no heating function) T-BAT H 5.8: 0 ~ 55 °C (no heating function)			
Storage temperature ^②	-30 ~ 80°C			
Relative humidity	5 ~ 95% (non-condensing)			
Altitude	3000 m			
Protection	IP65			
COMMUNICATION				
System to inverter	CAN + RS485			
Battery to battery / BMS	T30: CAN / T58: RS485			
Master control LED indicator working mode	1 LED			
Master control capacity indicator	2 x 4 LED (25%, 50%, 75%, 100%)			
Battery module LED	2 LED			
Switch on / off	Button x 1 + breaker x 1			
CERTIFICATION				
Safety	IEC / EN 62477-1, IEC / EN 61439-1, IEC / EN 61439-2			
EMC	EN 61000-6-1 / 2 / 3 / 4			
GENERAL				
Dimensions (W x H x D)	368 x 334 x 153.5 mm			
Weight	8.7 kg			
Expected life	5 years			
NOMINAL CHARACTER (BATTERY SYSTEM)				
Overvoltage category (OVC)	II			
Protective class	I			
Recommend charge / discharge current	25 A			
Max. charge / discharge current	35 A			
SYSTEM ONE (T58 PACK)				
	TP 5.8 G2	TP 5.8 G2	TP 5.8 G2	TP 5.8 G2
Nominal voltage	115.2 V	230.4 V	345.6 V	460.8 V
Operating voltage	100 ~ 131 V	200 ~ 262 V	300 ~ 393 V	400 ~ 524 V
Total capacity	11.5 kWh	23 kWh	34.6 kWh	46.1 kWh
Usable capacity ^③	10.3 kWh	20.7 kWh	31.1 kWh	41.4 kWh
Nominal power	2.8 kW	5.7 kW	8.6 kW	11.5 kW
Max. power ^④	4.0 kW	8.0 kW	12.0 kW	16.1 kW
SYSTEM TWO (T30 PACK)				
	TP 3.0 G2	TP 6.0 G2	TP 9.0 G2	TP 12.0 G2
Nominal voltage	102.4 V	204.8 V	307.2 V	409.6 V
Operating voltage	90 ~ 116 V	180 ~ 232 V	270 ~ 348 V	360 ~ 464 V
Total capacity	6.1 kWh	12.3 kWh	18.4 kWh	24.6 kWh
Usable capacity ^③	5.5 kWh	11.0 kWh	16.5 kWh	22.1 kWh
Nominal power	2.5 kW	5.1 kW	7.6 kW	10.2 kW
Max. power ^④	3.0 kW	6.1 kW	9.2 kW	12.2 kW

Reliable Performance

- Easily expand Capacity
- Extend battery lifespan

Flexible Adaptability

- Support two-column parallel connection
- Support T-BAT-SYS-HV-3.0, T-BAT-SYS-HV-5.8

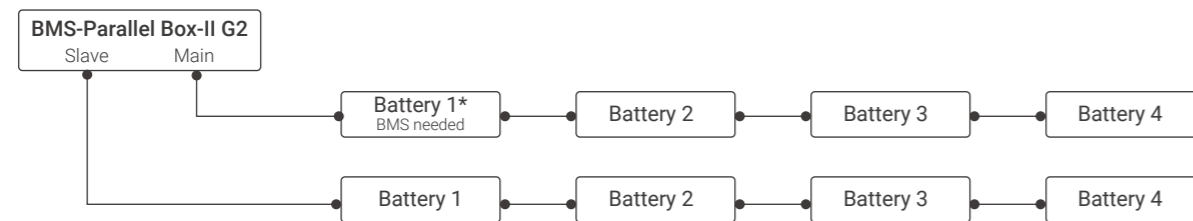

- Notes:
1. Battery 1 & 2 & 3 & 4 may refer to HV11550 or HV10230.
 2. Battery 1 & 2 & 3 & 4 models are required to be the same
 3. As for Battery 1*, a BMS is necessary, that is, T-BAT H 5.8 for T58, MC0600 + HV10230 for T30

① BMS parallel box G2 with different batteries has different system operating temperature
 ② This is the storage temperature of BMS parallel box G2, please refer to the battery storage problem for each battery
 ③ 90% DOD; System usable energy may vary with inverter different setting
 ④ Test conditions: 100% DOD, 0.2C charge & discharge @+25°C

Accessories

X3-EPS Parallel Box G2



Flexible Integration

- Convenient wiring

Reliable Performance

- Provide reliable backup power in parallel

*V2.4. Information may be subject to modify without notice. 650.00015.00

	X3-PBOX-60kW-G2	X3-PBOX-150kW-G2 ^①	X3-PBOX-300kW-G2
GRID (INVERTER)			
Grid connection	Three Phase		
Rated voltage	220 / 380 V, 230 / 400 V, 240 / 415 V		
AC frequency	50 Hz / 60 Hz		
AC output voltage range	(198 ~ 253 V) / (342 ~ 440 V)		
Maximum grid input current	87 A	217 A	478 A
EPS (INVERTER)			
Rated voltage	230 VA / 400 VA		
EPS frequency	50 Hz / 60 Hz		
Maximum No. of parallel inverters ^②	6	10	10
Maximum EPS input current per channel	21.7 A	43.5 A	95.6 A
Maximum EPS input current	87 A	217 A	478 A
LOAD (BACKUP)			
Load connection	Single Phase / Three Phase		
Rated voltage	220 / 380 V, 230 / 400 V, 240 / 415 V		
AC frequency	50 Hz / 60 Hz		
Maximum apparent power	60 kVA	150 kVA	300 kVA
Maximum output current	87 A	217 A	478 A
Switchover time	< 10 s		
GENERAL SPECIFICATION			
Operating temperature range	-25 ~ 40°C (-13 ~ 104°F)		
Relative humidity range	0 ~ 100% RH (condensing)		
Altitude	< 3000 m		
Dimensions (W × H × D)	492 × 478 × 183 mm	776 × 740 × 234 mm	880 × 1080 × 270 mm
Weight	17 kg	42.5 kg	100 kg
Degree of protection	IP65		

① This model comes in two versions: G2 and G2.1. The G2 version supports only X3-G4 and does not support X3-ULTRA, whereas the G2.1 version is compatible with both X3-G4 and X3-ULTRA
 ② This is related to the maximum power of X3-EPS Parallel Box and the maximum output power of the inverter. Taking X3-PBOX-300kW-G2 as an example, if the maximum output power of the connected inverter is 50kW, the maximum number of parallel machines is 6. If the maximum output power of the connected inverter is 30kW, the maximum number of parallel machines is 10

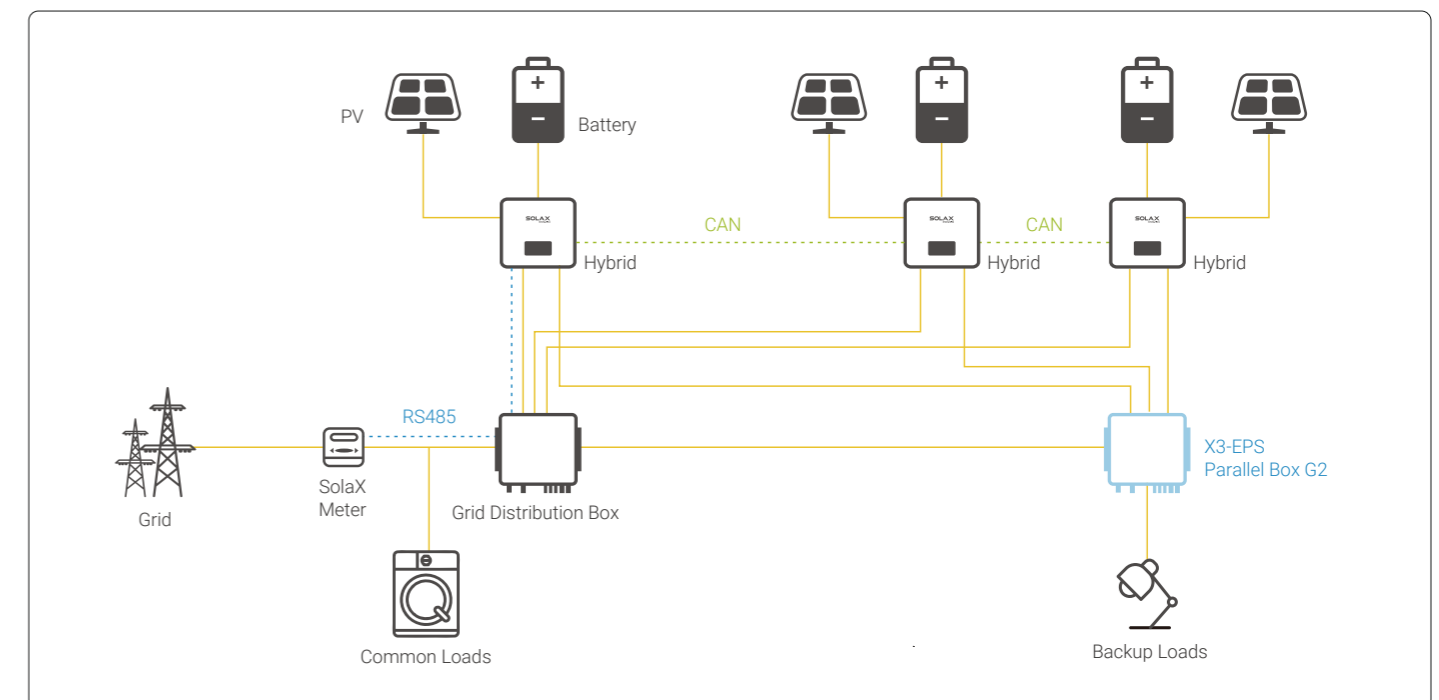

Accessories



TCBox-70

TCBOX-70	
Max. operation current	70 A
Input & output voltage	90 ~ 750 V
Communication interface	RJ45 × 4
Max. parallel tower	3
Available charge / discharge temperature range	-30 ~ 60 °C
Storage temperature	-40 ~ 80 °C
Relative humidity	0 ~ 95 %
Dimension (W x H x D)	325 × 231 × 126 mm
Weight	2.1 kg
Installation type	Wall mounted
Protection class	IP65
Cooling type	Natural
Altitude	< 3000 m

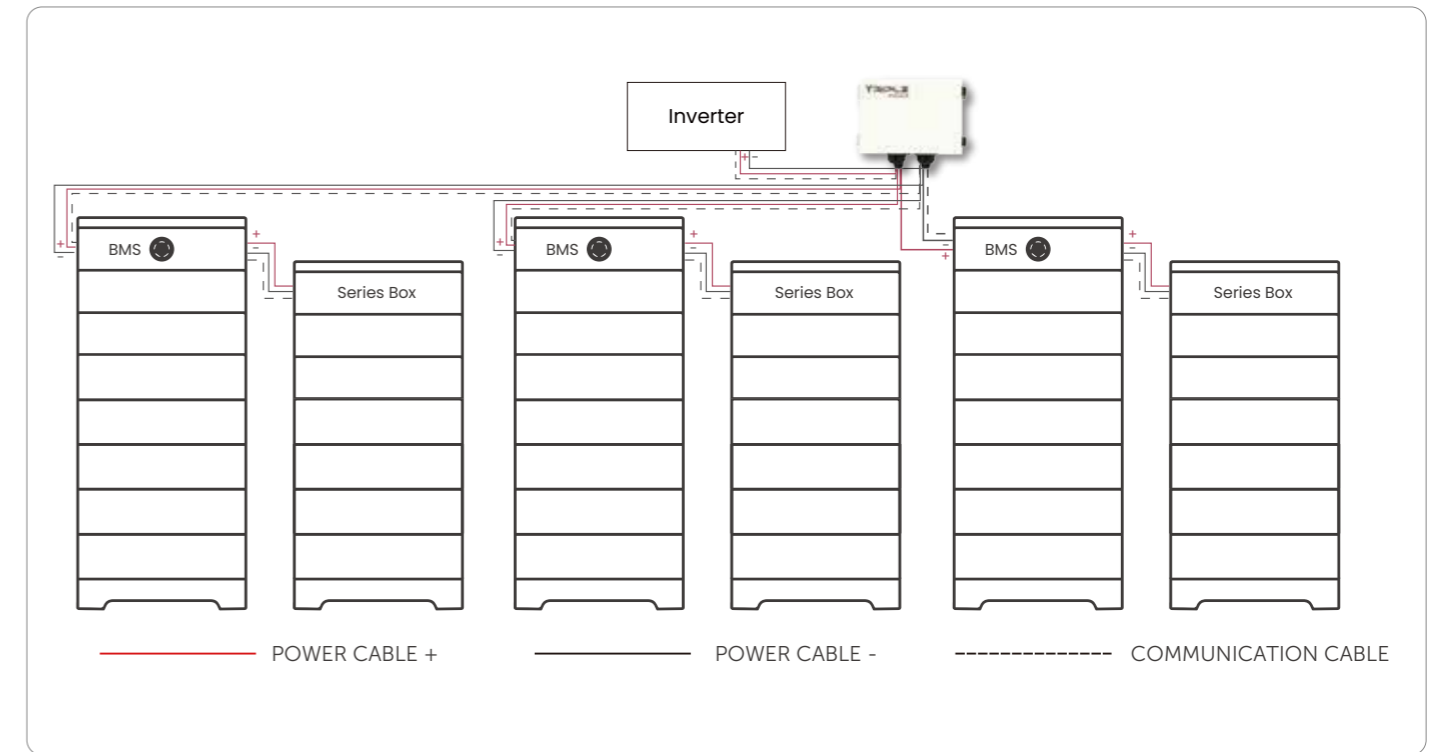

Reliable Performance

- Easy capacity expansion and extend battery lifespan
- Scalable, modular design

Flexible Adaptability

- Support three-column parallel connection
- Support T-BAT-SYS-HV-S2.5, T-BAT-SYS-HV-S3.6, T-BAT-SYS-HVS50E-D, TSYS-HS51*

* Compatibility with TSYS-HS51 will be upgraded in the future

Accessories



X1 EPS BOX X3 EPS BOX

EPS Box integrates two contactors which provide power steering for users. It is compatible with single-phase and three-phase inverters. Together with inverter, EPS Box can achieve intelligent switch between on-grid connection and off-grid connection. It can simplify the operation and improve security.

X1 EPS BOX

X3 EPS BOX

	GRID	
Max.AC input current	63 A	3 × 63 A
Rated AC voltage	230 V	3 / N / PE, 400 / 230 V
Rated AC frequency	50 / 60 Hz	50 / 60 Hz
	EPS	
Max.EPS input current	32 A	3 × 63 A
Rated EPS voltage	230 V	3 / N / PE, 400 / 230 V
Rated EPS frequency	50 / 60 Hz	50 / 60 Hz
	LOAD	
Rated output current, on grid mode	63 A	3 × 63 A*
Rated output current, EPS mode	32 A	3 × 63 A*
Rated grid voltage	230 V	3 / N / PE, 400 / 230 V
Rated grid frequency	50 / 60 Hz	50 / 60 Hz
	GENERAL DATA	
Operating temperature	-20 ~ 60°C	-20 ~ 60°C
Switch time	0.5 s	0.5 s
Dimension	300 × 220 × 170 mm	300 × 220 × 170 mm
Weight	3.5 kg	4.85 kg
Degree of protection	IP65	IP65

*: The output current will be reduced when the operating temperature exceeds 40°C. At 50°C, the output current drops to 95% . At 60°C, it drops to 80%.

 Supports whole-home backup

 Simplifies wiring with integrated dual contactors

Accessories

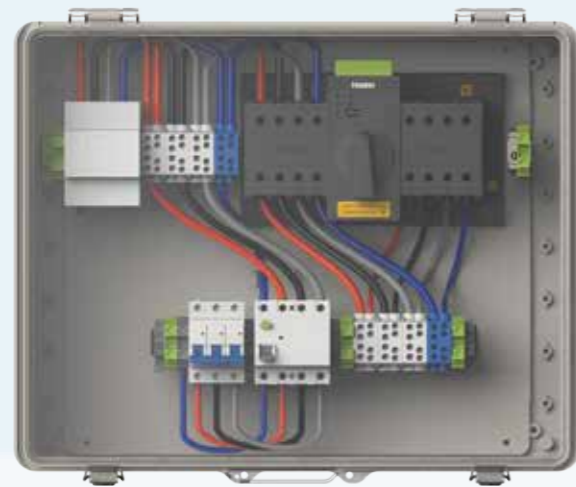

X3-EPS BOX G2

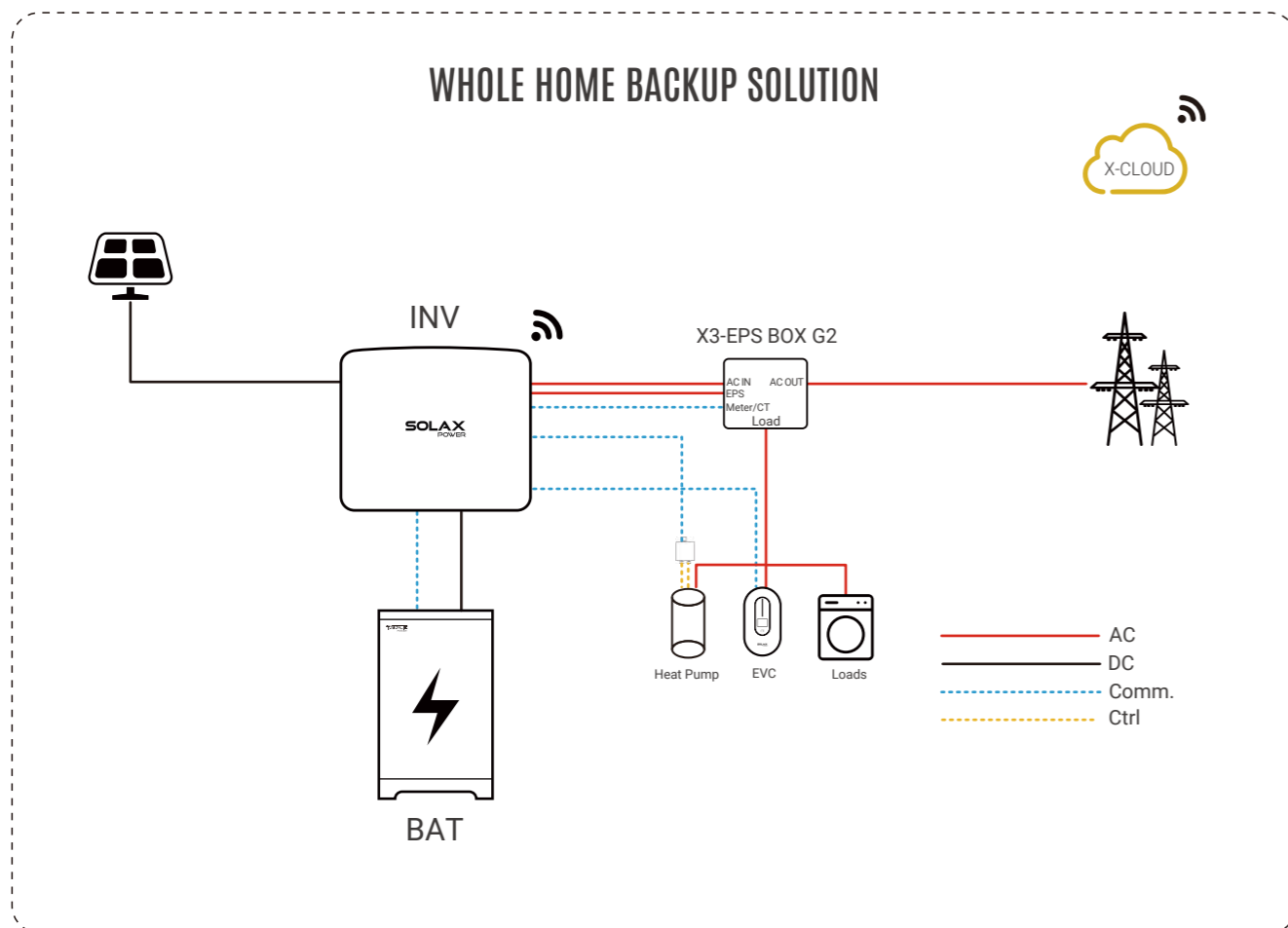

AC Switching Cabinet

ON-GRID(Inverter)	
Rated AC voltage	220 / 230 / 240 V
Rated AC frequency	50 / 60 Hz
Max.output apparent power	16500 VA
Max.output current	24 A
OFF-GRID(Inverter)	
Rated output voltage	230 VA
Rated AC frequency	50 / 60 Hz
Max.output apparent power	16500 VA
Max.output current	24 A
GRID(Utility)	
Rated grid voltage	220/230/240 V
Rated AC frequency	50 / 60 Hz
Max.input current	63 A
Max.output current	25 A
LOAD	
Rated AC voltage	220/230/240 V
Rated AC frequency	50 / 60 Hz
Max.current	63 A
ENVIRONMENT LIMIT	
Components	25 A × 3
Protective class	Class I
Shock resistance level	IK09
Operating temperature range	-35~60°C (> 45°C derating)
Storage temperature	-40~70°C
Relative humidity	0~100% RH (condensing)
Switchover time	≤ 1.8 s
Max.operating altitude	3000 m
Noise emission (typical)	< 30 dB(A)
Overvoltage category	Mains: III
ENVIRONMENT LIMIT	
Cooling concept	Nature cooling
DIMENSION AND WEIGHT	
Dimensions (W × H × D)	540 × 430 × 202 mm
Net weight	12.5 kg



SMART SOLAR, STORAGE & ENERGY SOLUTIONS
Residential Energy Storage LV

Single-phase Low-voltage Residential Hybrid Inverter



X1-HYB-LV

3.0kW / 3.7kW / 4.0kW
5.0kW / 6.0kW

Smart Management

- Global MPP scan for optimal energy harvest*
- Smart loads management

Assured Reliability

- Battery terminal temperature detection
- IP65 ingress protection
- Type II SPD on AC&DC side
- AFCI protection (optional)*
- Up to 200% EPS output for 10s
- Single unit UPS-level switchover time < 4 ms

High Performance

- Max. 2 MPPTs for versatile application scenarios
- 200% oversizing and 150% PV input power
- Max. 16 A PV input per MPPT
- Low start-up voltage for higher energy harvest

Flexible Adaptability

- Max. 3pcs parallel for on-grid and off-grid
- Micro-grid and generator function for versatile operations*

* Feature to be upgraded in the future

*V2.1 Information may be subject to modify without notice. 650.00023.00

	X1-HYB-3.0-LV	X1-HYB-3.7-LV	X1-HYB-4.0-LV	X1-HYB-5.0-LV	X1-HYB-6.0-LV
PV INPUT					
Max. recommended PV array power	6000 Wp	7360 Wp	8000 Wp	10000 Wp	12000 Wp
Max. PV input voltage ^①	550 V				
Rated PV input voltage	360 V				
Operating voltage range	80 ~ 520 V				
Start-up voltage	110 V				
No. of MPP trackers / strings per MPP tracker	2 / (1 / 1)				
Max. input current per MPPT	16 A / 16 A				
Max. input short circuit current per MPPT	20 A / 20 A				
AC INPUT & OUTPUT(ON-GRID)					
Rated output power	3000 W	3680 W	4000 W	5000 W	6000 W
Rated output current	13.1 A @ 230 V	16.0 A @ 230 V	17.4 A @ 230 V	21.8 A @ 230 V	26.1 A @ 230 V
Max. output apparent power	3300 VA	3680 VA	4400 VA	5000 VA	6000 VA
Max. output continuous current	14.4 A @ 230 V	16.0 A @ 230 V	19.2 A @ 230 V	21.8 A @ 230 V	26.1 A @ 230 V
Rated AC voltage	220 / 230 / 240 V				
Max. AC input apparent power	6000 VA	7360 VA	8000 VA	9200 VA	
Max. AC input current	26.1 A @ 230 V	32.0 A @ 230 V	34.8 A @ 230 V	40.0 A @ 230 V	
Max. continuous AC passthrough (grid to load)	40 A				
Rated AC frequency	50 Hz / 60 Hz				
AC frequency range ^②	50±5 Hz / 60±5 Hz				
Adjustable power factor range	~ 1 (0.8 lagging to 0.8 leading)				
THDi (rated power)	< 3%				
BATTERY					
Battery type	Lithium / Lead - acid				
Battery voltage range	40 ~ 60 V				
Max. charge / discharge current	75 A / 75 A			120 A / 120 A	
EPS (OFF-GRID) OUTPUT (WITH BATTERY)					
Rated EPS output voltage, frequency	230 V, 50 Hz / 60 Hz				
Rated EPS output power	3000 VA	3680 VA	4000 VA	5000 VA	6000 VA
Peak EPS output power	6000 VA 2 times of rated power, 10s	7360 VA 2 times of rated power, 10s	8000 VA 2 times of rated power, 10s	10000 VA 2 times of rated power, 10s	12000 VA 2 times of rated power, 10s
Switchover time	< 4 ms				
EFFICIENCY					
Max. efficiency	97.6%				
European efficiency	97.0%				
ENVIRONMENT LIMIT					
Ingress protection	IP65				
Operating temperature range	-25 ~ 60°C (> 45°C derating)				
Max. operating altitude	3000 m				
Relative humidity	4 ~ 100% RH (condensing)				
Overvoltage category	Mains: III, Battery: II, PV: II				
GENERAL					
Dimensions (W × H × D)	397 × 490 × 201 mm				
Net weight	16.5 kg			17.3 kg	
Cooling concept	Natural cooling			Smart air cooling	
Communication interfaces	RS485, CAN, USB, DI/DO				
Display	LCD				
Topology	Non-isolated for PV side / HF for battery side				
Certifications	NRS 097-2-1, IEC 61727, IEC 62116, PEA, MEA, BIS, EN IEC 62109-1 / -2				
PROTECTION					
Protections	Over / under voltage protection, DC isolation protection, DC reverse-polarity protection, Back feed current monitoring, Residual current detection, Active anti-islanding method, Over temperature protection				
Active anti-islanding method	Frequency shift				
Surge protection	DC: Type II, AC: Type II				
Arc-fault circuit interrupter (AFCI)	optional				

① The maximum input voltage is the upper limit of the DC voltage. Any higher input DC voltage would probably damage the inverter

② The AC frequency range may vary from different country codes

Single-phase Low-voltage Residential Hybrid Inverter



X1-RENO-LV

8kW

Smart Management

- Smart loads management
- Cloud monitoring and operations & maintenance
- Global MPP scan for optimal energy harvest*

High Performance

- 200% oversizing and 200% PV input power
- Max. 36A PV input per MPPT
- Low start-up voltage for higher energy harvest
- Up to 200% EPS output for 10s
- Single unit UPS-level switchover time < 4 ms

Assured Reliability

- Battery terminal temperature detection
- IP66 ingress protection
- Type II SPD on AC&DC side
- AFCI protection (optional)*

Flexible Adaptability

- Max. 5 pcs parallel for on-grid and off-grid
- Compatible with multiple third-party batteries
- Micro-grid and generator function for versatile operations*

* Feature to be upgraded in the future

*V1.3 Information may be subject to modify without notice. 650.00097.00

X1-RENO-8.0-LV

PV INPUT	
Max. recommended PV array power	16 kWp
Max. PV input voltage ^①	500 V
Rated PV input voltage	360 V
Operating voltage range	60 ~ 480 V
Start-up voltage	80 V
No. of MPP trackers / strings per MPP tracker	2 (2/2)
Max. input current per MPPT	36 A / 36 A
Max. input short circuit current per MPPT	45 A / 45 A
AC INPUT & OUTPUT (ON-GRID)	
Rated output power	8 kW
Rated output current	34.8 A@230 V
Max. output apparent power	8.8 kVA
Max. output continuous current	38.3 A@230 V
Rated AC voltage	220 / 230 / 240 V
Max. AC input apparent power	11 kVA
Max. AC input current	47.9 A@230 V
Max. continuous AC passthrough (grid to load)	50 A
Rated AC frequency	50 Hz / 60 Hz
AC frequency range ^②	50±5 Hz / 60±5 Hz
Adjustable power factor range	~ 1 (0.8 lagging to 0.8 leading)
THDi (rated power)	< 3%
BATTERY	
Battery type	LFP / Lead-acid
Battery voltage range	40 ~ 60 V
Max. charge / discharge current	190 A / 190 A
EPS (OFF-GRID) OUTPUT (WITH BATTERY)	
Rated EPS output voltage, frequency	230 V, 50 Hz / 60 Hz
Rated EPS output power	8 kVA
Peak EPS output power	16 kVA 2 times of rated power, 10s
Switchover time	< 4 ms
EFFICIENCY	
Max. efficiency	97.6%
European efficiency	97.0%
ENVIRONMENT LIMIT	
Ingress protection	IP66
Operating temperature range	-40°C ~ 60°C (> 45°C derating)
Max. operating altitude	3000 m
Relative humidity	4 ~ 100%RH (condensing)
Overvoltage category	Mains: III, Battery: II, PV: II
GENERAL	
Dimensions (W × H × D)	420 × 528.4 × 209mm
Net weight	26.3kg
Cooling concept	Smart air cooling
Communication interfaces	CAN, RS485, USB, DI/DO
Display	LCD
Topology	Non-isolated for PV side / HF for battery side
Certifications	NRS 097-2-1, IEC61727, IEC62116, INMETRO, IEC/EN 62109-1/-2
PROTECTION	
Protections	Over / under voltage protection, DC isolation protection, DC reverse-polarity protection, Grid monitoring, DC injection monitoring, Back feed current monitoring, Over temperature protection
Active anti-islanding method	Frequency shift
Surge protection (DC / AC)	DC: Type II, AC: Type II
Arc-fault circuit interrupter (AFCI)	Optional

① The maximum input voltage is the upper limit of the DC voltage. Any higher input DC voltage would probably damage the inverter

② The AC frequency range may vary from different country codes

Single-phase Low-voltage Residential Hybrid Inverter



X1-Lite-LV

8kW / 10kW / 12kW

Smart Management

- Global MPP scan for optimal energy harvest*
- Smart loads management

High Performance

- Max. 3 MPPTs for versatile application scenarios
- 200% oversizing and 200% PV input power
- Max. 32 A PV input per MPPT
- Low start-up voltage for higher energy harvest

Assured Reliability

- Battery terminal temperature detection
- IP65 ingress protection
- Type II SPD on AC&DC side
- AFCI protection (optional)*
- Up to 200% EPS output for 10s
- Single unit UPS-level switchover time < 6 ms

Flexible Adaptability

- Max. 3pcs parallel for on-grid and off-grid
- Micro-grid and generator function for versatile operations*

* Feature to be upgraded in the future

*V1.4. Information may be subject to modify without notice. 650.00061.00

	X1-Lite-8k-LV	X1-Lite-10k-LV	X1-Lite-12k-LV
PV INPUT			
Max. recommended PV array power	16000 Wp	20000 Wp	24000 Wp
Max. PV input voltage ^①	600 V		
Rated PV input voltage	360 V		
Operating voltage range	50 ~ 550 V		
Start-up voltage	110 V		
No. of MPP trackers / strings per MPP tracker	2 / (2 / 2)	3 / (2 / 2 / 2)	
Max. input current per MPPT	32 A / 32 A	32 A / 32 A / 32 A	
Max. input short circuit current per MPPT	40 A / 40 A	40 A / 40 A / 40 A	
AC INPUT & OUTPUT (ON-GRID)			
Rated output power	8000 W	10000 W	12000 W
Rated output current	34.8 A @ 230 V	43.5 A @ 230 V	52.2 A @ 230 V
Max. output apparent power	8800 VA	11000 VA	13200 VA
Max. output continuous current	38.3 A @ 230 V	47.9 A @ 230 V	57.4A @ 230 V
Rated AC voltage	220 / 230 / 240 V		
Max. AC input apparent power	12650 VA	14950 VA	18400 VA
Max. AC input current	55 A @ 230 V	65 A @ 230 V	80 A @ 230 V
Max. continuous AC passthrough (grid to load)	75 A	80 A	90 A
Rated AC frequency	50 Hz / 60 Hz		
AC frequency range ^②	50 ± 5 Hz / 60 ± 5 Hz		
Adjustable power factor range	~ 1 (0.8 lagging to 0.8 leading)		
THDi (rated power)	< 3%		
BATTERY			
Battery type	LFP / Lead - acid		
Battery voltage range	40 ~ 60 V		
Max. charge / discharge current	190 A / 190 A	220 A / 220 A	250 A / 250 A
EPS (OFF-GRID) OUTPUT (WITH BATTERY)			
Rated EPS output voltage, frequency	230 V, 50 Hz / 60 Hz		
Rated EPS output power	8000 VA	10000 VA	12000 VA
Peak EPS output power	16000 VA 2 times of rated power, 10s	20000 VA 2 times of rated power, 10s	24000 VA 2 times of rated power, 10s
Switchover time	< 6 ms		
EFFICIENCY			
Max. efficiency	97.6%		
European efficiency	97.0%		
ENVIRONMENT LIMIT			
Ingress protection	IP65		
Operating temperature range	-25 ~ 60°C (> 45°C derating)		
Max. operating altitude	3000 m		
Relative humidity	4 ~ 100% RH (condensing)		
Overvoltage category	Mains: III, Battery: II, PV: II		
GENERAL			
Dimensions (W × H × D)	462 × 651 × 280 mm		
Net weight	38.5 kg		
Cooling concept	Smart air cooling		
Communication interfaces	RS485, CAN, USB, DI/DO		
Display	LCD		
Topology	Non-isolated for PV side / HF for battery side		
Certifications	IEC/EN 62109-1/-2, NRS 097-2-1, IEC 61727, IEC 62116, PEA, MEA, BIS		
PROTECTION			
Protections	Over / under voltage protection, DC isolation protection, DC reverse-polarity protection, Grid monitoring, DC injection monitoring, Back feed current monitoring, Over temperature protection		
Active anti-islanding method	Frequency shift		
Surge protection (DC / AC)	DC: Type II, AC: Type II		
Arc-fault circuit interrupter (AFCI)	Optional		

① The maximum input voltage is the upper limit of the DC voltage. Any higher input DC voltage would probably damage the inverter
 ② The AC frequency range may vary from different country codes

Three-phase Low-voltage Residential Hybrid Inverter



X3-NEO-LV

5kW / 8kW / 10kW
12kW / 15kW / 20kW

Smart Management

- Global MPP scan for optimal energy harvest*
- Smart loads management

High Performance

- Max. 2 MPPTs for versatile application scenarios
- 200% oversizing and 200% PV input power
- Max. 36 A PV input per MPPT
- Low start-up voltage for higher energy harvest

Assured Reliability

- Battery terminal temperature detection
- IP65 ingress protection
- Type II SPD on AC&DC side
- AFCI protection (optional)*
- Up to 200% EPS output for 10s
- Single unit UPS-level switchover time < 3 ms

Flexible Adaptability

- Max. 3pcs parallel for on-grid and off-grid
- Micro-grid and generator function for versatile operations*

* Feature to be upgraded in the future

*V1.7 Information may be subject to modify without notice. 650.00078.00

	X3-NEO-5K-LV	X3-NEO-8K-LV	X3-NEO-10K-LV	X3-NEO-12K-LV	X3-NEO-15K-LV	X3-NEO-20K-LV
PV INPUT						
Max. recommended PV array power	10 kWp	16 kWp	20 kWp	24 kWp	30 kWp	40 kWp
Max. PV input voltage ^①	1000 V					
Rated PV input voltage	640 V					
Operating voltage range	160 ~ 950 V					
Start-up voltage	150 V					
No. of MPPT trackers / strings per MPPT tracker	2 / (1 / 1)		2 / (2 / 1)		2 / (2 / 2)	
Max. input current per MPPT	18 A / 18 A		36 A / 18 A		36 A / 36 A	
Max. input short circuit current per MPPT	25 A / 25 A		50 A / 25 A		50 A / 50 A	
AC INPUT & OUTPUT (ON-GRID)						
Rated output power	5 kW	8 kW	10 kW	12 kW	15 kW	20 kW
Rated output current	7.3 A @ 230 V	11.6 A @ 230 V	14.5 A @ 230 V	17.4 A @ 230 V	21.8 A @ 230 V	29.0 A @ 230 V
Max. output apparent power	5.5 kVA	8.8 kVA	11 kVA	13.2 kVA	16.5 kVA	22.0 kVA
Max. output continuous current	8.0 A @ 230 V	12.8 A @ 230 V	16.0 A @ 230 V	19.2 A @ 230 V	24.0 A @ 230 V	31.9 A @ 230 V
Rated AC voltage	3W / N / PE, 220 / 380 V 3W / N / PE, 230 / 400 V 3W / N / PE, 240 / 415 V					
Max. AC input apparent power	10 kVA	16 kVA	20 kVA	24 kVA	30 kVA	30 kVA
Max. AC input current	14.5 A @ 230 V	23.2 A @ 230 V	29.0 A @ 230 V	34.8 A @ 230 V	43.5 A @ 230 V	43.5 A @ 230 V
Max. continuous AC passthrough (grid to load)	40 A					
Rated AC frequency	50 Hz / 60 Hz					
AC frequency range ^②	50 ± 5 Hz / 60 ± 5 Hz					
Adjustable power factor range	~ 1 (0.8 lagging to 0.8 leading)					
THDi (rated power)	< 3%					
BATTERY						
Battery type	LFP / Lead - acid					
Battery voltage range	40 ~ 60 V					
Max. charge / discharge current	125 A / 125 A	200 A / 200 A	250 A / 250 A	280 A / 280 A	300 A / 300 A	350 A / 350 A
EPS (OFF-GRID) OUTPUT (WITH BATTERY)						
Rated EPS output voltage, frequency	230 V / 400 V, 50 Hz / 60 Hz					
Rated EPS output power	5 kVA	8 kVA	10 kVA	12 kVA	15 kVA	20 kVA
Peak EPS output power	10 kVA 2 times of rated power, 10s	16 kVA 2 times of rated power, 10s	20 kVA 2 times of rated power, 10s	24 kVA 2 times of rated power, 10s	30 kVA 2 times of rated power, 10s	40 kVA 2 times of rated power, 10s
Switchover time	< 3 ms					
EFFICIENCY						
Max. efficiency	97.6%					
European efficiency	97.0%					
ENVIRONMENT LIMIT						
Ingress protection	IP65					
Operating ambient temperature range	-25 ~ 60°C (> 45°C derating)					
Max. operation altitude	3000 m					
Relative humidity	4 ~ 100% RH (condensing)					
Overvoltage category	Mains: III, Battery: II, PV: II					
GENERAL						
Dimensions (W × H × D)	520 × 705 × 258 mm					
Net weight	44.6 kg					45.2 kg
Cooling concept	Natural cooling			Smart air cooling		
Communication interfaces	RS485, CAN, USB, DI/DO					
Display	LCD					
Topology	Non-isolated for PV side / HF for battery side					
Certifications	EN IEC 62109-1 / -2, NRS 097-2-1, IEC 61727, IEC 62116, PEA, MEA, BIS, G98 / G99 ^③					
PROTECTION						
Protections	Over / under voltage protection, DC isolation protection, DC reverse-polarity protection, Grid monitoring, DC injection monitoring, Back feed current monitoring, Residual current detection, Over temperature protection					
Active anti-islanding method	Frequency shift					
Surge protection	DC: Type II, AC: Type II					
Arc-fault circuit interrupter (AFCI)	Optional					

① The maximum input voltage is the upper limit of the DC voltage. Any higher input DC voltage would probably damage the inverter

② The AC frequency range may vary from different country codes

③ G98 certification covers 5-10kw power ranges and G99 covers 12-15kw. 20kW will be certificated in future

Low-voltage Battery System



LD51C

5.1 kWh



High Performance

- 5.1 ~ 81.9 kWh wide capacity range
- Max. 100 A / 135 A charge / discharge current
- Cycle life > 6000 cycles



Assured Reliability

- IP40 ingress protection
- LFP battery cell & high-performance processors



Smart Management

- Remote fault diagnosis, upgrade and maintenance
- Wide temperature tolerance
- User-friendly LCD touchscreen for intuitive and easy interaction



Flexible Adaptability

- Expandable to 16 units in parallel
- CTP (Cell-to-Pack) design maximizes space and energy density for superior performance

LD51C

GENERAL INFORMATION

Battery model	LD51C
Battery type	LFP
Scalability	Max. 16 pcs in parallel
Rated voltage	51.2 Vdc
Operating voltage range	42.4 ~ 57.6 Vdc
Rated energy	5.1 kWh
Usable energy (95% DOD) ^①	4.8 kWh
Rated power	2.5 kW
Max. power	6.9 kW
Peak output power	10.2 kW, 10s
Recommend charge / discharge current	50 A
Max. charge / discharge current ^②	100 A / 135 A
Depth of discharge	95%
Cycle life (95% DOD) ^③	> 6000 cycles
Dimensions (W x H x D)	370 x 635 x 183 mm
Net weight	42.8 ± 1 kg
Warranty	5 Years

ENVIRONMENTAL REQUIREMENTS

Charge temperature	0 ~ +55°C
Discharge temperature	-20 ~ +55°C
Cooling concept	Natural cooling
Storage temperature	-20 ~ +30°C (12 months) +30 ~ +60°C (6 months)
Relative humidity	5 ~ 95% RH (non-condensing)
Max. operating altitude	3000 m
Installation type	Wall mounting / Floor mounting
Ingress protection	IP40
Environment	Indoor

COMMUNICATION INTERFACES

Display	Indicators / LCD
Communication interfaces	CAN2.0 / RS485

STANDARD

Hazardous materials classification	Class 9
Transport testing requirement	UN38.3
Protection class	Class I
Certifications	IEC 62477, IEC 62619, IEC 60730, IEC 63056, IEC 61000, EMC

① Test conditions: 95% DOD, 0.5C charge & discharge @+25°C

② Current is affected by the number of batteries connected in parallel as well as temperature and SOC

③ Test conditions: 25 ± 2°C, 0.5C charge & discharge, 70%EOL

Low-voltage Battery System



T-BAT-SYS-LV D53

5.3 kWh

High Performance

- 5.3 ~ 85.1 kWh wide capacity range
- Max. 100 A / 100 A charge / discharge current^①
- Cycle life > 6000 cycles

Assured Reliability

- IP65 ingress protection
- LFP battery cell & high-performance processors

Smart Management

- Remote fault diagnosis, upgrade and maintenance
- Wide temperature tolerance

Flexible Adaptability

- Expandable to 16 units in parallel
- Quick and easy installation

T-BAT-SYS-LV D53

GENERAL INFORMATION	
Battery model	TP-LD53
Battery type	LFP
Scalability	Max. 16 pcs in parallel
Rated voltage	51.2 Vdc
Operating voltage range	45 ~ 58 Vdc
Rated energy	5.3 kWh
Usable energy (95% DOD) ^②	5.03 kWh
Rated power	2.6 kW
Max. power	6.1 kW
Peak output power	7.7 kW, 10 s
Recommend charge / discharge current	50 A
Max. charge / discharge current ^①	100 A / 100 A
Depth of discharge	95%
Cycle life (95% DOD) ^③	>6000 cycles
Dimensions (WxHxD)	430 × 645 × 150 mm
Net weight	48.5 kg
Warranty	10 Years
ENVIRONMENTAL REQUIREMENTS	
Charge temperature	0 ~ +53°C
Discharge temperature	-20 ~ +53°C
Cooling concept	Natural cooling
Storage Temperature	-20 ~ +30°C (12 months) +30 ~ +50°C (6 months)
Relative humidity	4 ~ 100% RH (condensing)
Max. operating altitude	3000 m
Installation type	Wall mounting / Floor mounting
Ingress protection	IP65
Environment	Outdoor / indoor
COMMUNICATION INTERFACES	
Display	Indicators
Communication interfaces	CAN2.0 / RS485
STANDARD	
Hazardous materials classification	Class 9
Transport testing requirement	UN38.3
Protection class	Class I
Certifications	IEC62619, IEC62040, CE

① Current is affected by the number of batteries connected in parallel as well as temperature and SOC; At the temperature of 25 °C, the maximum discharge current can reach 120A.

② Test conditions: 95% DOD, 0.5C charge & discharge @+25°C

③ Test conditions: 25 ± 2°C, 0.5C charge & discharge, 70%EOL

Low-Voltage Battery System



TSYS-LD117

11.7 kWh



High Performance

- 11.7 ~ 187.2 kWh wide capacity range
- Max.230A/230A charge / discharge current^①
- Cycle life > 6000 cycles



Assured Reliability

- IP40 ingress protection
- LFP battery cell & high-performance processors
- Aerosol fire suppression for precise protection



Smart Management

- Remote fault diagnosis, upgrade and maintenance
- Wide temperature tolerance
- User-friendly LCD touchscreen for intuitive and easy interaction



Flexible Adaptability

- Expandable to 16 units in parallel
- CTP (Cell-to-Pack) design maximizes space and energy density for superior performance

TSYS-LD117

GENERAL INFORMATION

Battery model	TB-117
Battery type	LFP
Scalability	Max. 16 pcs in parallel
Nominal voltage	51.2 Vdc
Operating voltage range	42.4 ~ 57.6 Vdc
Nominal energy	11.7 kWh
Usable energy (95% DOD) ^②	11.1 kWh
Rated power	5.8 kW
Max. power	12.8 kW
Peak output power	23.5 kW, 10s
Recommend charge / discharge current	115 A
Max. charge / discharge current ^①	230 A / 230 A
Depth of discharge	95%
Cycle life (95% DOD) ^③	> 6000 cycles
Dimensions (W x H x D)	355 x 726 x 263 mm
Net weight	88 kg
Warranty	5 Years

ENVIRONMENTAL REQUIREMENTS

Charge temperature	0 ~ 55°C
Discharge temperature	-20 ~ 55°C
Cooling concept	Natural cooling
Storage temperature	-20 ~ 30°C (12 months) 30 ~ 60°C (6 months)
Relative humidity	5 ~ 95% RH (non-condensing)
Max. operating altitude	3000 m
Installation type	Wall mounting / floor mounting
Ingress protection	IP40
Environment	Indoor

COMMUNICATION INTERFACES

Display	Indicators / LCD
Communication interfaces	CAN2.0 / RS485

STANDARD

Hazardous materials classification	Class 9
Transport testing requirement	UN38.3
Protection class	Class I
Certifications	IEC 62619, CE

^① Current is affected by the number of batteries connected in parallel as well as temperature and SOC.

At the temperature of 25°C, the maximum discharge current can reach 250A and last for 30 minutes.

^② Test conditions: 95% DOD, 0.5C charge & discharge @+25°C

^③ Test conditions: 25 ± 2°C, 0.5C charge & discharge, 70%EOL

Low-voltage Battery System



TSYS-LD160
16.0 kWh



TSYS-LD143
14.3 kWh

High Performance

- 16 ~ 256 kWh (LD160) / 14.3 ~ 229.3 kWh (LD143) wide capacity range
- Max. 155 A / 220 A (LD160), 140 A / 225 A (LD143) charge / discharge current
- Cycle life > 8000 cycles

Smart Management

- Remote fault diagnosis, upgrade and maintenance
- Wide temperature tolerance
- User-friendly LCD touchscreen for intuitive and easy interaction

Assured Reliability

- IP40 ingress protection
- LFP battery cell & high-performance processors
- Aerosol fire suppression for precise protection

Flexible Adaptability

- Expandable to 16 units in parallel
- CTP (Cell-to-Pack) design maximizes space and energy density for superior performance
- Pulley design enables more convenient installation

*V1.0. Information may be subject to modify without notice. 650.00121.00

	TSYS-LD160	TSYS-LD143
GENERAL INFORMATION		
Battery model	TB-LD160	TB-LD143
Battery type	LFP	
Scalability	Max. 16 pcs in parallel	
Nominal voltage	51.2 Vdc	
Operating voltage range	42.4 ~ 57.6 Vdc	
Nominal energy	16 kWh	14.3 kWh
Usable energy (95% DOD) ^①	15.2 kWh	13.6 kWh
Rated power	7.9 kW	7.1 kW
Max. power	11.2 kW	11.5 kW
Peak output power	15.8 kW, 10s	14.3 kW, 10s
Recommend charge / discharge current	155 A	140 A
Max. charge / discharge current ^②	155 A / 220 A	140 A / 225 A
Depth of discharge	95%	
Cycle life (95% DOD) ^③	> 8000 cycles	
Dimensions (W x H x D)	356 x 953 x 289mm	
Net weight	118.5 kg	115.5 kg
Warranty	5 Years	
ENVIRONMENTAL REQUIREMENTS		
Charge temperature	0 ~ +55°C	
Discharge temperature	-20 ~ +55°C	
Cooling concept	Natural cooling	
Storage temperature	-20 ~ +30°C (12 months) 30 ~ +60°C (6 months)	
Relative humidity	5 ~ 95% RH (non-condensing)	
Max. operating altitude	3000 m	
Installation type	Floor mounting	
Ingress protection	IP40	
Environment	Indoor	
COMMUNICATION INTERFACES		
Display	Indicators / LCD	
Communication interfaces	CAN2.0 / RS485	
STANDARD		
Hazardous materials classification	Class 9	
Transport testing requirement	UN38.3	
Protection class	Class I	
Certifications	IEC 62619, CE-LVD, CE-EMC	

① Test conditions: 95% DOD, 0.5C charge & discharge @+25°C

② Current is affected by the number of batteries connected in parallel as well as temperature and SOC

③ Test conditions: 25 ± 2°C, 0.5C charge & discharge, 70%EOL

Low-voltage Battery System



TP-LD150

15.0 kWh



High Performance

- 15 ~ 240 kWh wide capacity range
- Max. 155 A charge/discharge current
- Cycle life > 6000 cycles



Assured Reliability

- IP65 ingress protection
- LFP battery cell & high-performance processors



Smart Management

- Remote fault diagnosis, upgrade and maintenance
- Wide temperature tolerance



Flexible Adaptability

- Expandable to 16 units in parallel
- Quick and easy installation

TP-LD150

GENERAL INFORMATION

Battery model	TP-LD150
Battery type	LFP
Scalability	Max. 16 pcs in parallel
Rated voltage	48 Vdc
Operating voltage range	42 ~ 54 Vdc
Rated energy	15.0 kWh
Usable energy (90% DOD) ^①	13.5 kWh
Rated power	7.4 kW
Max. power	7.4 kW
Peak output power	15.0 kW, 10s
Recommend charge / discharge current	155 A
Max. charge / discharge current ^②	155 A
Depth of discharge	90%
Cycle life (90% DOD) ^③	> 6000 cycles
Dimensions (W × H × D)	540 × 900 × 220 mm
Net weight	125 kg
Warranty	5 Years

ENVIRONMENTAL REQUIREMENTS

Charge temperature	0 ~ +55°C
Discharge temperature	-20 ~ +55°C
Cooling concept	Natural cooling
Storage temperature	-20 ~ +30°C (12 months) +30 ~ +60°C (6 months)
Relative humidity	4 ~ 100% RH (condensing)
Max. operating altitude	3000 m
Installation type	Floor mounting
Ingress protection	IP65
Environment	Outdoor / indoor

COMMUNICATION INTERFACES

Display	Indicators
Communication interfaces	CAN2.0 / RS485

STANDARD

Hazardous materials classification	Class 9
Transport testing requirement	UN38.3
Protection class	Class I
Certifications	IEC62619, CE

① Test conditions: 90% DOD, 0.5C charge & discharge @+25°C

② Current is affected by the number of batteries connected in parallel as well as temperature and SOC

③ Test conditions: 25 ± 2°C, 0.5C charge & discharge, 70%EOL

Single-Phase Residential Off-Grid Inverter



OG SERIES

5kW / 6kW



Intelligent Operation and Maintenance

- Built-in WiFi enables easy remote monitoring
- Removable dust filter for quick replacement



Assured Reliability

- Seamless switching ensures uninterrupted power supply (< 4 ms)
- Super-backup without battery in off-grid situation



High Performance

- Maximum PV input current up to 28A, easily compatible with high-power modules
- Max. 120A charge/ 140A discharge current, 20% more than industry average
- Up to 200% AC output overloading capability for 5s



Flexible Adaptability

- Smart load management via independent generator port
- Support up to 3 units in parallel and more planned in the future
- Compatibility with multiple battery types and broader applicability

	0G548	0G648
PV INPUT		
Max. recommended PV array power	6 kWp	7.2 kWp
Max. PV input voltage ^①	450 d.c. V	
Rated PV input voltage	360 d.c. V	
Operating voltage range	90 - 450 d.c. V	
Start-up voltage	95 d.c. V	
No. of MPP trackers / strings per MPP tracker	1 / 1	
Max. input current per MPPT	20 d.c. A	28 d.c. A
AC INPUT		
Max. input apparent power	9.2 kVA	
Max. input current	40.0 a.c. A@230 a.c. V	
Rated AC input voltage	230 a.c. V	
Rated AC input frequency	50 Hz / 60 Hz	
Switchover time	< 4ms (typical)	
BATTERY		
Battery type	Lithium / Lead - acid	
Rated battery voltage	48 d.c. V	
Battery voltage range	40 - 60 d.c. V	
Max. charge / discharge current	100 / 120 d.c. A	120 / 140 d.c. A
AC OUTPUT		
Rated output power	5 kW	6 kW
Rated output current	21.8 a.c. A@230 a.c. V	26.1 a.c. A@230 a.c. V
Max. output apparent power	5 kVA	6 kVA
Max. output continuous current	21.8 a.c. A@230 a.c. V	26.1 a.c. A@230 a.c. V
Peak output power	10 kW 2 times of rated power, 5s	12 kW 2 times of rated power, 5s
Rated AC output voltage	230 a.c. V	
Rated AC output frequency	50 Hz / 60 Hz	
EFFICIENCY		
Max. efficiency	96.5%	
ENVIRONMENT LIMIT		
Ingress protection	IP20	
Operating temperature range	-10 - 55°C	
Max. operating altitude	3000 m	
Relative humidity	5 - 90% RH (non-condensing)	
Overvoltage category	Mains: III, Battery: II, PV: II	
GENERAL		
Dimensions (W × H × D)	320 × 395 × 115 mm	
Net weight	9.6 kg	
Cooling concept	Smart air cooling	
Communication interfaces	CAN, WiFi, RS485	
Display	LCD	
Topology	Non-isolated	
Certifications	CE	

① The maximum input voltage is the upper limit of the DC voltage. Any higher input DC voltage would probably damage inverter



=====

SMART SOLAR, STORAGE & ENERGY SOLUTIONS
Commercial & Industrial Energy Storage



X3-AELIO

49.9kW / 50kW / 60kW / 61kW

Flexible Configuration

- Parallel operation: supports up to 10 parallel systems, meeting power requirements from 49.9 kW to 600 kW.
- Battery options: three battery choices available.
- PV oversizing: supports up to 200% PV oversizing.

Safe and Reliable

- Three-Phase unbalance: Inverter supports 100% three-phase unbalance.
- Long-Term overload: inverter supports 110% long-term overload.
- Seamless switching: inverter supports 10ms on-grid/off-grid switching.
- Off-Grid overload: inverter supports 150% off-grid overload.

Intelligent and Convenient

- Remote monitoring: supports web/app remote data viewing and remote OTA updates.
- Versatile operating modes: supports various operating modes to meet different application scenarios such as self-consumption, peak shaving, and demand management.
- VPP Integration: supports VPP applications through IEEE2030.5, OpenADR.※
- Generator control: work seamlessly with generator to save fuel and back up

※ Feature to be upgraded in the future

*V1.0 Information may be subject to modify without notice. 650.00132.00

	X3-AELIO-49.9K	X3-AELIO-49.9K-P	X3-AELIO-50K	X3-AELIO-60K	X3-AELIO-61K
PV INPUT					
Max. recommended PV array power	100 kWp	120 kWp	100 kWp	120 kWp	120 kWp
Max. PV input voltage ^①	1000 V				
Rated PV input voltage	650 V				
MPPT voltage range ^②	160 ~ 950 V				
Start-up voltage	180 V				
No. of MPP trackers / Strings per MPP tracker	5 / 2	6 / 2	5 / 2	6 / 2	6 / 2
Max. input current per MPPT	40 A				
Max. input short circuit current per MPPT	50 A				
AC INPUT & OUTPUT (ON-GRID)					
Rated output power	49.9 kW	49.9 kW	50.0 kW	60.0 kW	61.0 kW
Rated output current	75.7 A @ 220 V 72.4 A @ 230V	75.7 A @ 220 V 72.4 A @ 230V	75.8 A @ 220 V 72.5 A @ 230V	91.0 A @ 220 V 87.0 A @ 230V	92.5 A @ 220 V 88.5 A @ 230V
Max. output apparent power	49.9 kVA	49.9 kVA	55.0 kVA	66.0 kVA	66.0 kVA
Max. output continuous current	75.7 A @ 220 V 72.4 A @ 230V	75.7 A @ 220 V 72.4 A @ 230V	83.4 A @ 220 V 79.8 A @ 230V	100.0 A @ 220 V 95.7 A @ 230V	100.0 A @ 220 V 95.7 A @ 230V
Rated AC voltage	3 / N / PE, 220 / 380 V 3 / N / PE, 230 / 400 V				
Rated AC frequency	50 Hz / 60 Hz				
AC frequency range ^③	50 ± 5 Hz / 60 ± 5 Hz				
Adjustable power factor range	~ 1 (0.8 lagging to 0.8 leading)				
THDi (rated power)	< 3%				
BATTERY					
Battery type	LFP				
Battery voltage range	180~ 820 V				
Max. charge / discharge current	160 A (80 A × 2)				
EPS (OFF-GRID) OUTPUT					
Rated EPS output voltage, frequency	3 / N / PE, 220 / 380 V, 50 Hz / 60 Hz 3 / N / PE, 230 / 400 V, 50 Hz / 60 Hz				
Rated EPS output power	49.9 kVA	49.9 kVA	50.0 kVA	60.0 kVA	61.0 kVA
Max EPS output power	75 kVA, 10s	75 kVA, 10s	75 kVA, 10s	90 kVA, 10s	90 kVA, 10s
Switchover time	< 10 ms				
EFFICIENCY					
Max. efficiency	98.0%				
European efficiency	97.2%				
ENVIRONMENT LIMIT					
Ingress protection	IP66				
Operating temperature range	-35 ~ 60°C (derating +45°C)				
Max. operating altitude	3000 m				
Relative humidity	0 ~ 100% RH (condensing)				
Overvoltage category	Mains: III, Battery: II, PV: II				
GENERAL					
Dimensions (W × H × D)	820 × 670 × 257 mm				
Net weight					
Cooling concept	< 100 kg	< 105 kg	Smart fan cooling	< 105 kg	< 105 kg
Communication interfaces	RS485-Meter, RS485-Monitor, RS485-Parallel(daisy-chain), CAN-BMS, CAN-Parallel(daisy-chain), USB, DI×2, DO×1, RCR(DI×4), DRM				
Topology	Non-isolated				
Certificates and approvals	CE, VDE4105, G99, AS4777, EN50549, CEI 0-21, IEC61727, PEA/MEA, NRS-097-2-1, RD1699, TOR				
PROTECTION					
Over / under voltage protection	Yes				
DC isolation protection	Yes				
DC reverse-polarity protection	Yes				
Grid monitoring	Yes				
DC injection monitoring	Yes				
Back feed current monitoring	Yes				
Residual current detection	Yes				
Over temperature protection	Yes				
Active anti-islanding method	Frequency shift				
Surge protection (DC / AC)	DC: Type II, AC: Type II				
Arc-fault circuit interrupter (AFCI)	Optional				
AC auxiliary power supply (APS)	Built-in				

① The maximum input voltage is the upper limit of the DC voltage. Any higher input DC voltage would probably damage inverter

② Input voltage exceeding the MPPT voltage range may triggers inverter protection

③ The AC frequency range may vary from different country codes

TSYS-HS51



T-HS25.6 T-HS30.7 T-HS35.8 T-HS40.9 T-HS46.0 T-HS51.2 T-HS56.3 T-HS61.4 T-HS66.5

SYSTEM SPECIFICATION									
	T-HS25.6	T-HS30.7	T-HS35.8	T-HS40.9	T-HS46.0	T-HS51.2	T-HS56.3	T-HS61.4	T-HS66.5
Number of modules	5	6	7	8	9	10	11	12	13
Rated energy	25.6 kWh	30.7 kWh	35.8 kWh	40.9 kWh	46.0 kWh	51.2 kWh	56.3 kWh	61.4 kWh	66.5 kWh
Usable energy (90% DOD) ^①	23.0 kWh	27.6 kWh	32.2 kWh	36.8 kWh	41.4 kWh	46.0 kWh	50.6 kWh	55.2 kWh	59.8 kWh
Rated voltage	256.0 V	307.2 V	358.4 V	409.6 V	460.8 V	512.0 V	563.2 V	614.4 V	665.6 V
Operation voltage range	212 ~ 289 V	255 ~ 347 V	297 ~ 405 V	340 ~ 463 V	382 ~ 520 V	424 ~ 578 V	467 ~ 636 V	509 ~ 694 V	552 ~ 750 V
Rated operation current ^②	60 A								
Maximum operation current ^{②③}	70 A								
Rated power ^③	15.4 kW	18.4 kW	21.5 kW	24.6 kW	27.6 kW	30.7 kW	33.8 kW	36.9 kW	39.9 kW
Max. power ^③	17.9 kW	21.5 kW	25.1 kW	28.7 kW	32.3 kW	35.8 kW	39.4 kW	43.0 kW	46.6 kW
Depth of discharge	90%								
Communication interfaces	CAN + RS485								
Dimensions (W x H x D)	600 x 1125 x 376 mm	600 x 1293 x 376 mm	600 x 1461 x 376 mm	600 x 1629 x 376 mm	600 x 957 x 376 mm + 600 x 1125 x 376 mm	600 x 1125 x 376 mm + 600 x 1125 x 376 mm	600 x 1293 x 376 mm + 600 x 1125 x 376 mm	600 x 1293 x 376 mm + 600 x 1125 x 376 mm	600 x 1461 x 376 mm + 600 x 1125 x 376 mm

BMS

Model	TBMS-S51-8
Dimensions (W x H x D)	600 x 225 x 376 mm
Net weight	18.5 kg

BATTERY MODULE

Model	TB-HS51
Battery type	LFP
Cycle life (90% DOD)	>6000 cycles
Module capacity	5.1 kWh
Dimensions (W x H x D)	600 x 168 x 376 mm
Net weight	46 kg
Installation type	Stackable

SERIES BOX

Dimensions (W x H x D)	600 x 225 x 376 mm
Net weight	15 kg

GENERAL SPECIFICATION

Installation	Floor mounting	
Charge temperature	-30 ~ +53°C (with heating function)	0 ~ +53°C (without heating function)
Discharge temperature	-30 ~ +53°C (with heating function)	-20 ~ +53°C (without heating function)
Relative humidity	4 ~ 100% RH (non-condensing)	
Altitude	< 3000 m	
Environment	Outdoor / indoor	
Ingress protection	IP66	

STANDARD

Certifications	IEC62619, IEC62040, EN62477, VDE 2510
Transport testing requirement	UN38.3

① Test conditions: 90% DOD, 0.2C charge & discharge @ 25°C
 ② Max. charge / discharge current may be variant with different inverter models
 ③ Nominal / maximum operation current and rated / maximum power derating will occur related to temperature or SOC

BATTERY MODULE COMBINATION TABLE

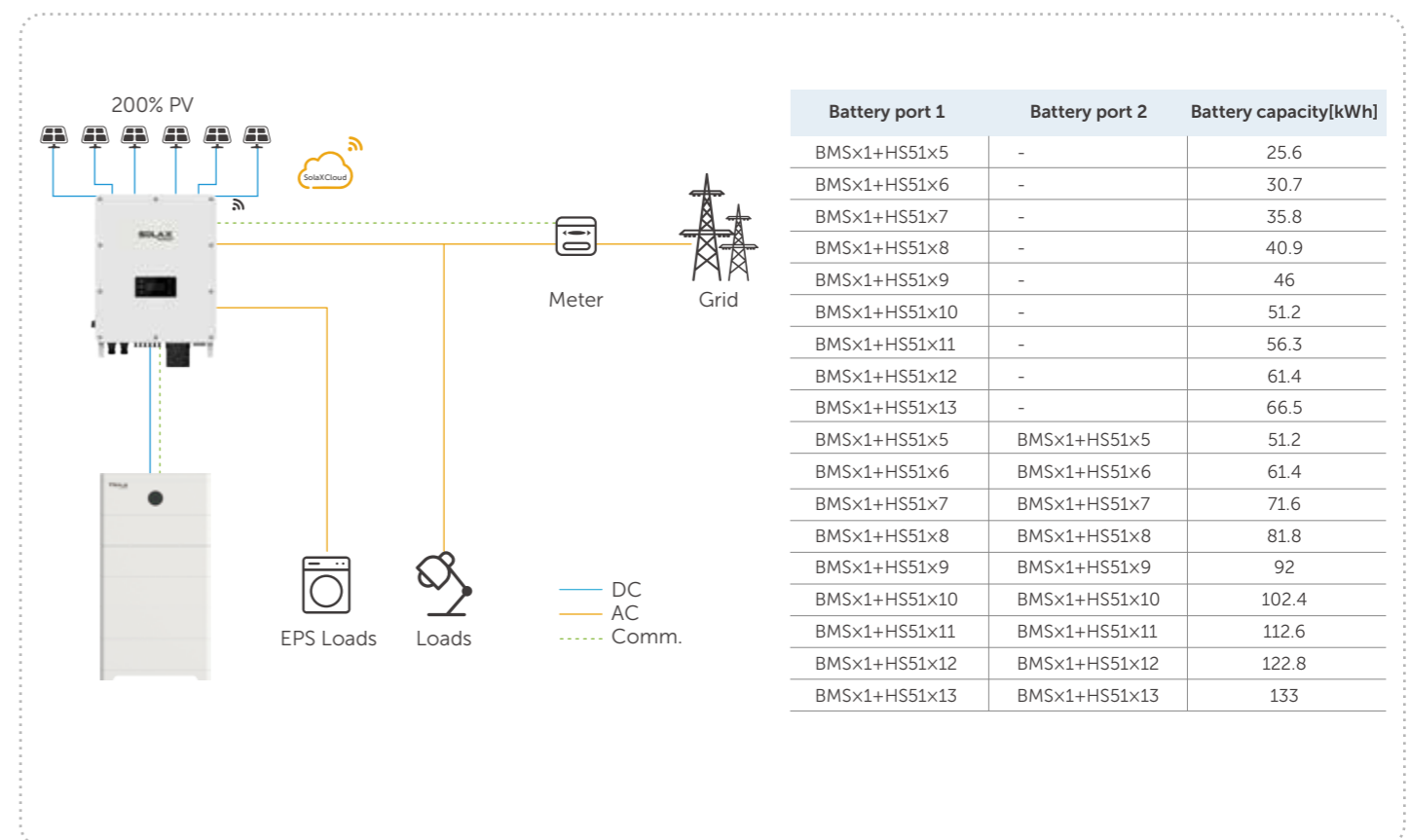

Battery port 1	Battery port 2	Battery capacity[kWh]
BMSx1+HS51x5	-	25.6
BMSx1+HS51x6	-	30.7
BMSx1+HS51x7	-	35.8
BMSx1+HS51x8	-	40.9
BMSx1+HS51x9	-	46
BMSx1+HS51x10	-	51.2
BMSx1+HS51x11	-	56.3
BMSx1+HS51x12	-	61.4
BMSx1+HS51x13	-	66.5
BMSx1+HS51x5	BMSx1+HS51x5	51.2
BMSx1+HS51x6	BMSx1+HS51x6	61.4
BMSx1+HS51x7	BMSx1+HS51x7	71.6
BMSx1+HS51x8	BMSx1+HS51x8	81.8
BMSx1+HS51x9	BMSx1+HS51x9	92
BMSx1+HS51x10	BMSx1+HS51x10	102.4
BMSx1+HS51x11	BMSx1+HS51x11	112.6
BMSx1+HS51x12	BMSx1+HS51x12	122.8
BMSx1+HS51x13	BMSx1+HS51x13	133

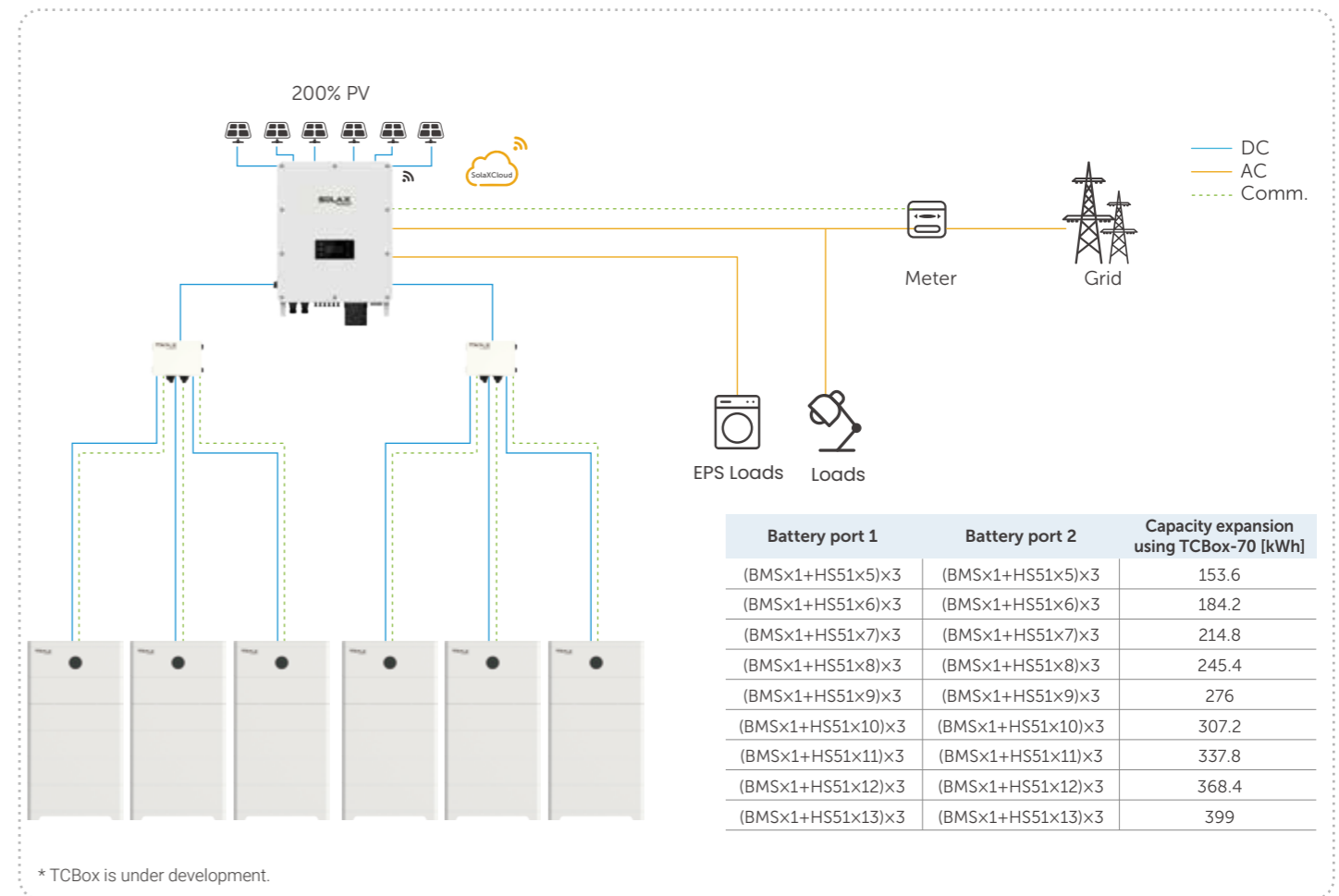

Battery port 1	Battery port 2	Capacity expansion using TCBox-70 [kWh]
(BMSx1+HS51x5)x3	(BMSx1+HS51x5)x3	153.6
(BMSx1+HS51x6)x3	(BMSx1+HS51x6)x3	184.2
(BMSx1+HS51x7)x3	(BMSx1+HS51x7)x3	214.8
(BMSx1+HS51x8)x3	(BMSx1+HS51x8)x3	245.4
(BMSx1+HS51x9)x3	(BMSx1+HS51x9)x3	276
(BMSx1+HS51x10)x3	(BMSx1+HS51x10)x3	307.2
(BMSx1+HS51x11)x3	(BMSx1+HS51x11)x3	337.8
(BMSx1+HS51x12)x3	(BMSx1+HS51x12)x3	368.4
(BMSx1+HS51x13)x3	(BMSx1+HS51x13)x3	399

* TCBox is under development.

TSYS-HR76

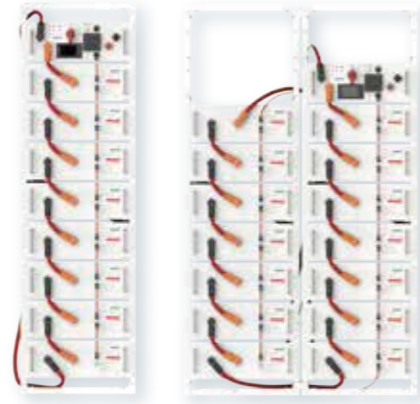

T-HR38.4 T-HR46.0 T-HR53.7 T-HR61.4 T-HR69.2 T-HR76.8 T-HR84.4 T-HR92.1 T-HR99.8 T-HR107.5

SYSTEM SPECIFICATION

Module quantities	5	6	7	8	9	10	11	12	13	14
Nominal energy	38.4 kWh	46.0 kWh	53.7 kWh	61.4 kWh	69.1 kWh	76.8 kWh	84.4 kWh	92.1 kWh	99.8 kWh	107.5 kWh
Usable energy (90%DOD)	34.5 kWh	41.4 kWh	48.3 kWh	55.2 kWh	62.2 kWh	69.1 kWh	76.0 kWh	82.9 kWh	89.8 kWh	96.7 kWh
Nominal voltage	256.0 V	307.2 V	358.4 V	409.6 V	460.8 V	512.0 V	563.2 V	614.4 V	665.6 V	716.8 V
Operation voltage range	200 ~ 292 V	240 ~ 350.4 V	280 ~ 408.8 V	320 ~ 467.2 V	360 ~ 525.6 V	400 ~ 584 V	440 ~ 642.4 V	480 ~ 700.8 V	520 ~ 759.2 V	560 ~ 817.6 V
Recommend charge / discharge current ^①	90 A									
Max. charge / discharge current ^①	150 A									
Rated power ^①	23.0 kW	27.6 kW	32.2 kW	36.8 kW	41.4 kW	46.0 kW	50.6 kW	55.2 kW	59.8 kW	64.5 kW

BATTERY MODULE

Battery model	TB-HR76
Nominal energy	7.68 kWh
Nominal voltage	51.2 V
Rated capacity	150 Ah
Cycle life (90% DOD)	≥ 6000 (@25°C ± 2°C, 0.5C / 0.5C, 70%EOL)
Battery Type	LFP
Dimensions (W x H x D)	450 x 170 x 580 mm
Net weight	60 kg

BMS

Model	TBMS-R76
Dimensions (W x H x D)	450 x 180 x 580 mm
Net weight	20 kg

RACK

Dimensions (W x H x D)	530 x 1800 x 600 mm	1110 x 1800 x 600 mm
Net weight	38.5 kg	77 kg

GENERAL

Battery roundtrip efficiency (0.5C / 0.5C, 25°C)	95%
Operating temperature range ^①	0 ~ 55°C (charge) -20 ~ 55°C (discharge)
Communication interface	CAN
Installation type	Rack mounting
Relative humidity	5 ~ 85% (non-condensing)
Max. operation altitude	3000 m
Environment	Indoor
Ingress protection	IP20
Certifications	IEC 62619 IEC 60730 IEC 63056 IEC 61000
Transport testing requirement	UN38.3

① The current is affected by temperature and SOC.

BATTERY MODULE COMBINATION TABLE

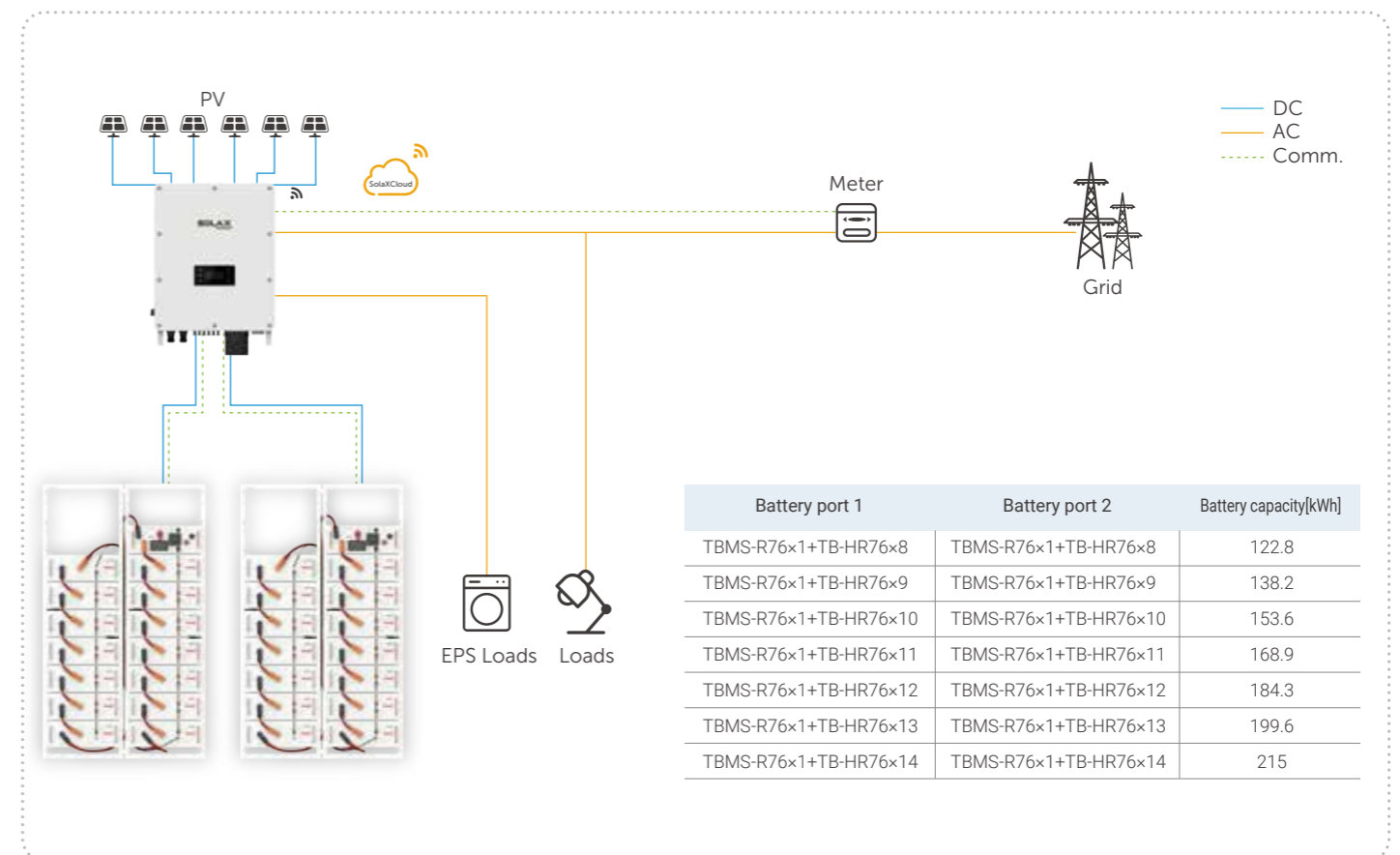
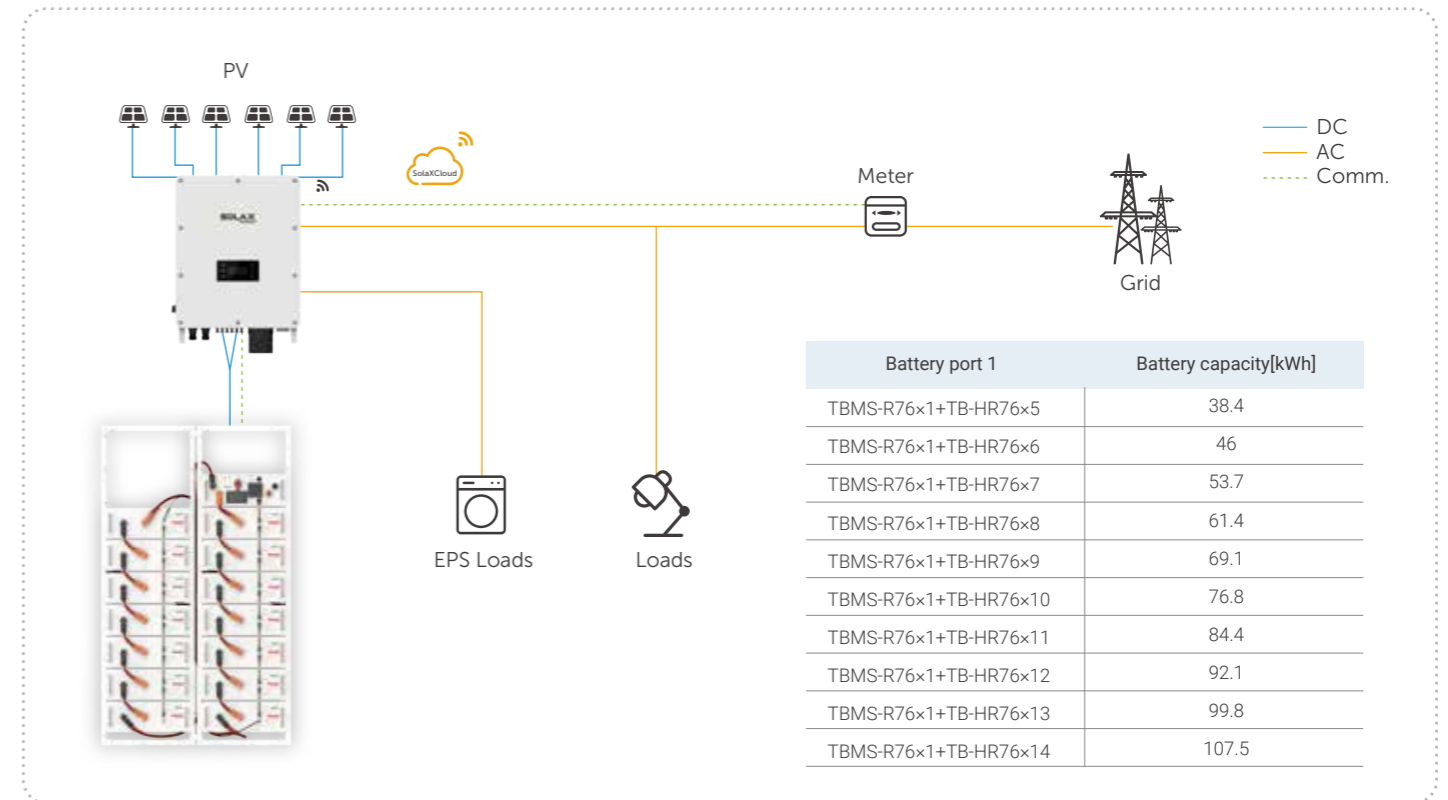

Rated / Maximum operation current and Rated / maximum power derating will occur related to temperature or SOC

TSYS-HR140



T-HR100.1 T-HR114.4 T-HR128.7 T-HR143.0 T-HR157.3 T-HR171.6 T-HR185.9 T-HR200.2

SYSTEM SPECIFICATION								
Scalability	7	8	9	10	11	12	13	14
Nominal capacity	100.1 kWh	114.4 kWh	128.7 kWh	143.0 kWh	157.3 kWh	171.6 kWh	185.9 kWh	200.2 kWh
Usable energy (90%DOD)	90.1 kWh	103.0 kWh	115.8 kWh	128.7 kWh	141.6 kWh	154.4 kWh	167.3 kWh	180.2 kWh
Nominal voltage	358.4 V	409.6 V	460.8 V	512 V	563.2 V	614.4 V	665.6 V	716.8 V
Operation voltage range	292 ~ 409 V	333 ~ 468 V	375 ~ 526 V	416 ~ 584 V	458 ~ 643 V	500 ~ 701 V	541 ~ 760 V	583 ~ 818 V
Recommend charge / discharge current ^②	140 A							
Max. charge / discharge current	154 A							
Rated charge / discharge power	50.2 kW	57.4 kW	64.6 kW	71.7 kW	78.9 kW	86.1 kW	93.2 kW	100.4 kW

BATTERY MODULE	
Battery model	TB-HR140
Module capacity	14.3 kWh
Rated module voltage	51.2 V
Module capacity	280 Ah
Cycle life (90% DOD)	> 6000 Cycles
Battery type	LFP
Dimensions (W x H x D)	523 x 226 x 805 mm
Net weight	115 kg
BMS	
Model	TBMS-R15
Dimensions (W x H x D)	523 x 226 x 805 mm
Net weight	37 kg
RACK	
Dimension (W x H x D)	576 x 2287 x 823 mm
Net weight	91 kg
GENERAL	
Battery roundtrip efficiency (0.2C, 25°C)	95%
Operating temperature range	0°C - 53°C (charge) -20°C - 53°C (discharge)
Communication interfaces	CAN
Installation type	Rack mounting
Relative humidity	5 ~ 85% (non-condensing)
Max.operation altitude	3000 m
Environment	Indoor
Protection degree	IP20
Safety	EN 62477, IEC 62619
Transport testing requirement	UN38.3

BATTERY MODULE COMBINATION TABLE

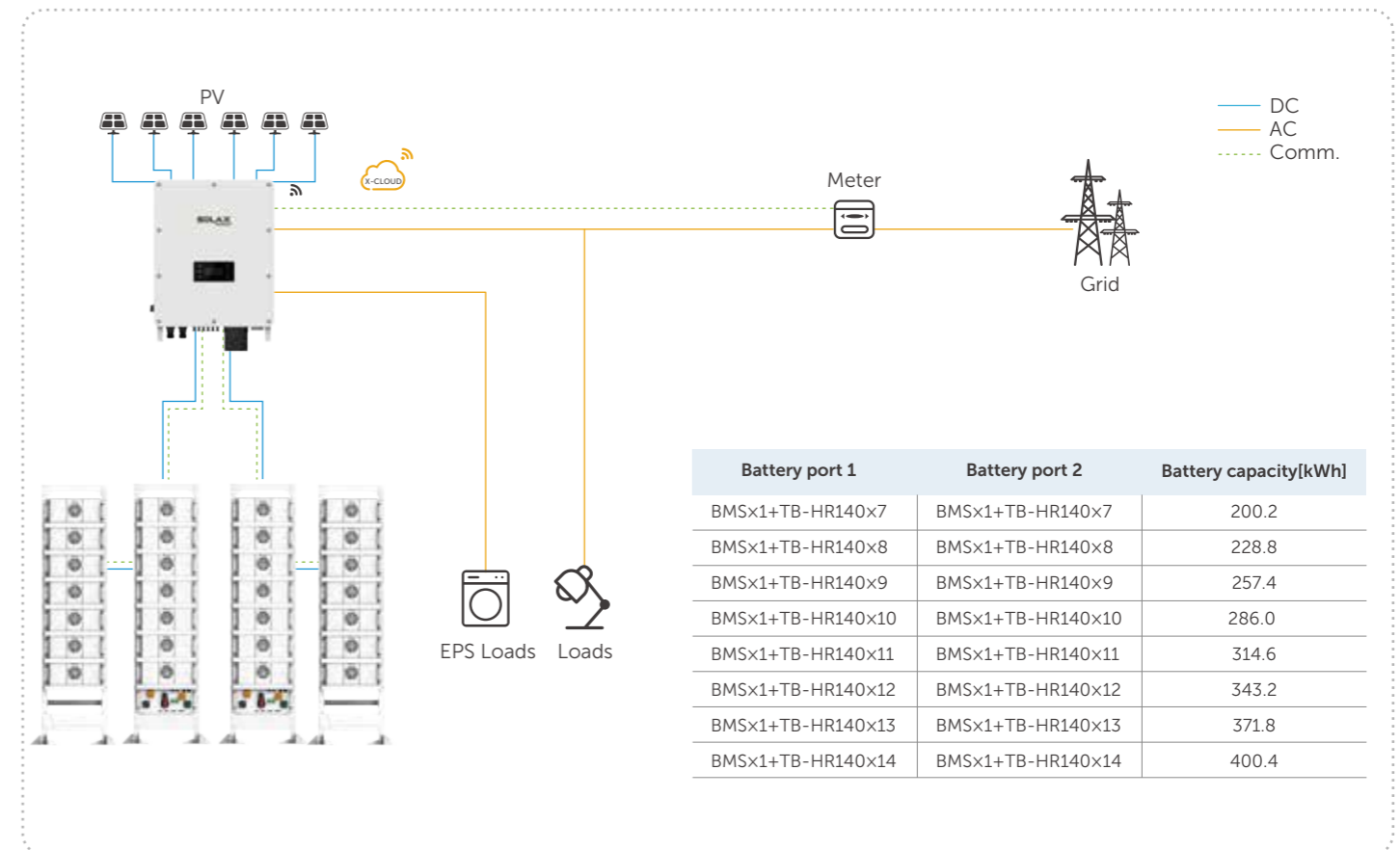
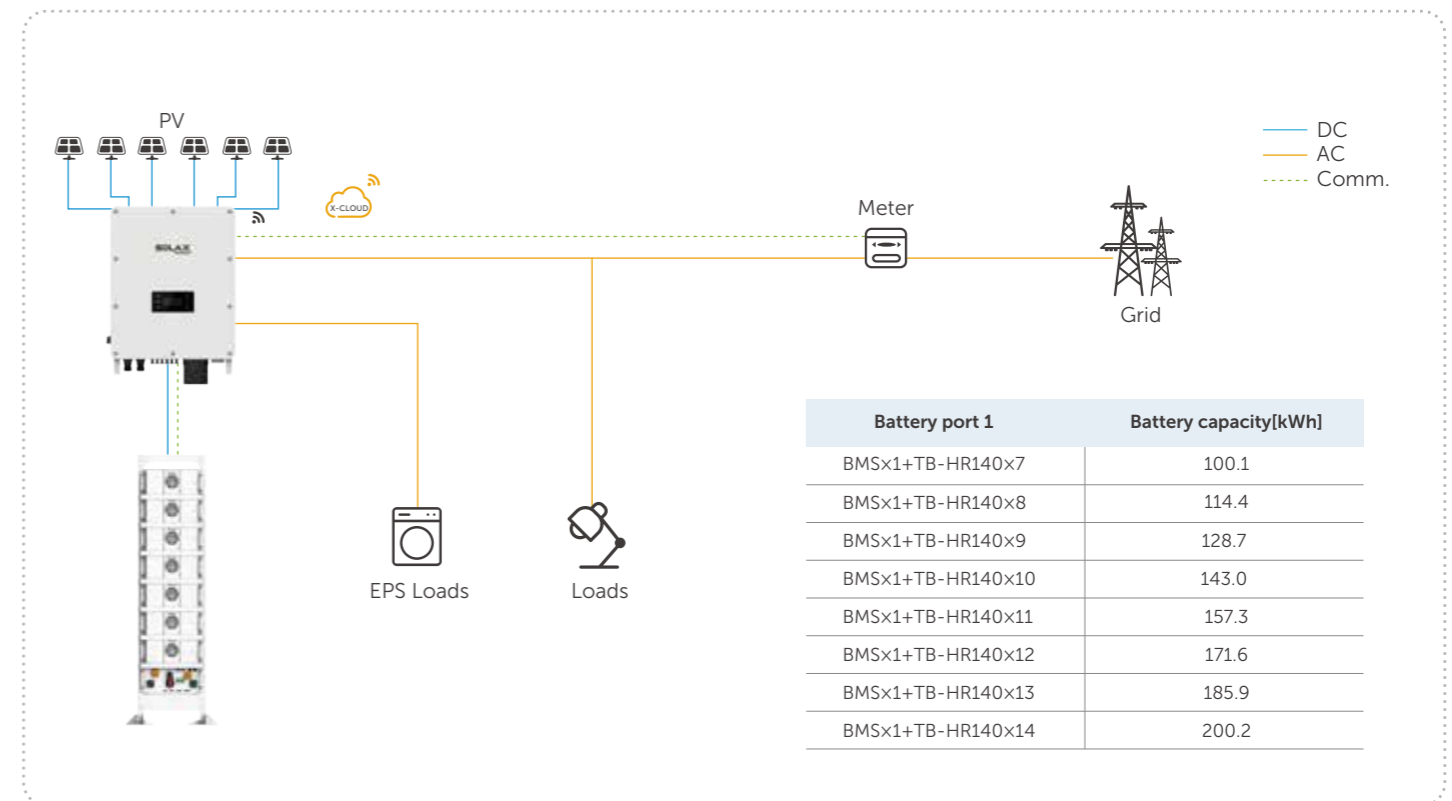

① Test conditions: 90% DOD, 0.2C charger & discharger @ 25°C
 ② Max. charge / discharge current may be variant with different inverter models
 ③ Nominal / Maximum operation current and nominal / maximum power derating will occur related to temperature or SOC

Hybrid ESS Cabinet



ESS-AELIO

50kW / 60kW
100 / 200kWh

High Performance

- Max. 200% PV oversizing input
- Global MPP scan for optimal energy harvest
- Single cabinet with up to 200kWh, expandable to MWh-scale capacity

Smart Management

- AI-driven intelligent algorithms for high SOC and accuracy
- VPP ready with SolaXCloud (IEEE 2030.5, OpenADR)
- Supporting micro-grids and diverse scenarios
- Smart schedule, smart scene and 7x24h TOU
- Wireless meter compatibility

Assured Reliability

- Four-level fire safety protection
- IP66 for inverter, IP55 for cabinet
- Type II SPD on AC & DC side
- Smart IV curve scan for early panel diagnosis
- Optional AFCI protection
- Supporting three-phase unbalance output

Flexible Adaptability

- Supporting grid-connected and off-grid
- Expandable design with modular capacity options
- Max. 40A DC input current for high power solar panel

ENERGY STORAGE SYSTEM

	AELIO-P50B100	AELIO-P50B200	AELIO-P60B100	AELIO-P60B200
DC SIDE				
Max. recommended PV array power	100 kWp		120 kWp	
Max. PV input voltage ^①	1000 V			
Start-up voltage	180 V			
Rated PV input voltage	650 V			
MPPT voltage range ^②	160 ~ 950 V			
No. of MPP trackers / strings per MPP tracker	5 / 2		6 / 2	
Max. input current per MPPT	40 A			
Isc PV array short circuit current per MPPT ^③	50 A			
AC SIDE				
Rated output power	50.0 kW		60.0 kW	
Rated output current	75.8 A @ 220 V 72.5 A @ 230 V		91.0 A @ 220 V 87.0 A @ 230 V	
Max. apparent power	55.0 kVA		66.0 kVA	
Max. output continuous current	83.4 A @ 220 V 79.8 A @ 230 V		100.0 A @ 220 V 95.7 A @ 230 V	
Nominal AC voltage	3 / N / PE, 220 / 380 V 3 / N / PE, 230 / 400 V			
Rated AC frequency	50 Hz / 60 Hz			
Adjustable power factor range	~1 (0.8 leading ~ 0.8 lagging)			
THDi (rated power)	< 3%			
BATTERY SIDE				
Battery type	LFP / 280 Ah			
Rated battery capacity	100 kWh	200 kWh	100 kWh	200 kWh
Rated battery voltage	358.4 V	716.8 V	358.4 V	716.8 V
Battery voltage range	296.8 ~ 408.8 V	596.3 ~ 817.6 V	296.8 ~ 408.8 V	596.3 ~ 817.6 V
Rated charge / discharge current	140 A			
GENERAL				
Dimensions (with inverter) (W × H × D)	1310 × 2300 × 1140 mm	2070 × 2420 × 1200 mm	1310 × 2300 × 1140 mm	2070 × 2420 × 1200 mm
Dimensions (without inverter) (W × H × D)	1020 × 2300 × 1140 mm	1680 × 2420 × 1200 mm	1020 × 2300 × 1140 mm	1680 × 2420 × 1200 mm
Weight (with inverter)	1600 kg	2800 kg	1600 kg	2800 kg
Weight (without inverter)	1500 kg	2700 kg	1500 kg	2700 kg
Operation temperature range	-30 ~ 55°C	-30 ~ 50°C	-30 ~ 55°C	-30 ~ 50°C
Relative humidity	0 ~ 100% RH (non-condensing)			
Max. operation altitude	3000 m			
Cooling concept	Smart air cooling			
Ingress protection	Cabinet: IP55; Inverter: IP66			
Fire protection	Aerosol / Water			
Topology	Non-isolated			
Certifications	IEC62619, IEC63056:2000, IEC61000, IEC62477-1, UN38.3, IEC 60730, IEC 60529, IEC 60068, VDE 2510-50, IEC62040, UL9540A			

① The maximum input voltage is the upper limit of the DC voltage. Any higher input DC voltage would probably damage inverter
 ② Input voltage exceeding the MPPT voltage range may trigger inverter protection
 ③ Isc current for single PV input string is 35A

AC-coupled ESS Cabinet



ESS-TRENE (Air cooling)

100kW / 215kWh

High Performance

- High power density, compact design
- Scalable up to megawatt-hours
- Optimised space utilisation

Smart Management

- Advanced energy management system
- VPP ready with SolaXCloud (IEEE 2030.5, OpenADR)
- Supporting micro-grids and diverse scenarios
- Smart schedule, smart scene and 7x24h TOU
- Wireless meter compatibility

Assured Reliability

- Four-level fire safety protection
- IP66 for inverter, IP55 for cabinet
- LFP battery cell & high-performance processors
- Type II SPD on AC side
- Advanced fault detection and response
- Supporting three-phase unbalance output

Flexible Adaptability

- Supporting grid-connected and off-grid (with SolaX switching cabinet)
- Full-stack self-developed BMS, EMS, PCS & SolaXCloud
- One year of historical data storage

TRENE-P100B215

AC SIDE (ON-GRID)	
Rated output power	100 kW
Max. output apparent power	110 kVA
Rated output current	151.9 A @380 V 144.4 A @400 V
Max. output continuous current	167.1 A @380 V 158.8 A @400 V
Rated AC voltage	3 / N / PE, 220 / 380 V 3 / N / PE, 230 / 400 V
AC voltage range	340 ~ 460 V
Rated AC frequency	50 Hz / 60 Hz
Adjustable power factor range	-1 ~ +1
Total harmonic distortion (THDi)	< 3% (rated power)
DC component	< 0.5% (rated power)
AC SIDE (OFF-GRID)	
Rated AC output voltage	3 / N / PE, 220 / 380 V 3 / N / PE, 230 / 400 V
Rated AC frequency	50 Hz / 60 Hz
THDv (linear load)	< 3% (linear load)
Unbalance load capacity (off-grid)	100%
Overloading capability	110%, long term; 120%, 1min
Max. AC output continuous current	151.9 A @380 V 144.4 A @400 V
DC SIDE	
Battery type	LFP / 280 Ah
Battery capacity	215 kWh
Rated battery voltage	768 V
Battery voltage range	650 ~ 876 V
SYSTEM PARAMETER	
Dimensions (W x H x D)	1680 x 2420 x 1200 mm
Net weight	2800 kg
Operating temperature range	-30 ~ 50°C (>45°C derating)
Relative humidity	0~95% RH (non-condensing)
Max. operating altitude	3000 m
Cooling concept	Smart air cooling
Ingress protection	IP55
Topology	Non-isolated
Certifications	IEC62619, IEC63056, IEC61000, IEC62477-1, IEC62040, UN38.3, GB/T36276, GB/T34131
Communication interfaces	Ethernet
Communication protocol	Modbus TCP
Anti-corrosion degree	C4 (C5 optional)
Configuration of safety	Gas fire suppression + Water-based fire suppression + Ventilation
Max.Parallel quantity (off-grid)	10

C&I ESS CABINET PCS

X3-TRENE-100K

AC SIDE (ON-GRID)	
Rated AC output apparent power	100 kW
Max. AC output apparent power	110 kVA
Rated AC output current	151.9 A @380 V 144.4 A @400 V
Max. AC output continuous current	167.1 A @380 V 158.8 A @400 V
Rated AC voltage	3 / N / PE, 220 / 380 V 3 / N / PE, 230 / 400 V
AC voltage range	320 ~ 460V
Rated AC frequency	50 Hz / 60 Hz
AC frequency Range	50 ± 5 Hz / 60 ± 5 Hz
Adjustable power factor range	-1 ~ +1
Total harmonic distortion (THDi)	< 3% (rated power)
DC component	< 0.5% (rated power)
Unbalance load capacity (on-grid)	100%
AC SIDE(OFF-GRID)	
Rated AC output voltage	3 / N / PE, 220 / 380 V 3 / N / PE, 230 / 400 V
Rated AC frequency	50 Hz / 60 Hz
THDv (linear load)	< 3% (linear load)
Unbalance load capacity (off-grid)	100%
Overloading capability	110%, long term; 120%, 1min
Max. AC output continuous current	167.1 A @380 V 158.8 A @400 V
DC SIDE	
Battery voltage range	650 ~ 936 V
Max. continuous charge / discharge current	161.8 A
GENERAL	
Max. Efficiency	98.0%
Ingress protection	IP66
Operating temperature range	-30 ~ 55°C (>45°C derating)
Max. operating altitude	3000 m
Relative humidity	0~95% RH (non-condensing)
Dimensions (W×H×D)	310 × 665 × 880 mm
Net weight	85 kg
Cooling concept	Smart air cooling
Communication interfaces	RS485 / CAN / Ethernet / DI

C&I ESS CABINET PCS

X3-TRENE-100K

PROTECTION	
Protections	AC over / under voltage protection, DC component monitoring, AC input phase sequence error protection, Grid frequency high / low protection, Communication failure protection, Type II SPD on AC side, etc.
STANDARD	
Certifications	CE, EN50549, VDE4105, G99, AS4777, CEI 0-21, IEC61727, PEA / MEA, NRS-097-2-1, RD1699, TOR

C&I ESS CABINET PACK

TB-HR140

Battery type	LFP 280 Ah
Battery capacity	14.3 kWh
Battery configuration	1P16S
Rated battery voltage	51.2 V
Battery voltage range	40 ~ 58.4 V
Weight	115 kg
Dimensions (W × H × D)	461 × 228 × 778 mm
Charge / discharge current	140 A
Max. operating altitude	3000 m
Ingress protection	IP20
Communication	CAN

If there is any change in product size and parameters, please refer to the latest information without prior notice.

AC-coupled ESS Liquid Cooling Cabinet



ESS-TRENE (Liquid cooling)

125kW /261kWh

High Performance

- Premium LFP battery with guaranteed quality
- High power density, compact design
- Scalable up to MWh
- Optimised space utilisation

Assured Safety

- 4+1 Fire safety design secures minimal risk and loss
- Aerosol Fire Suppression for Precise Protection
- IP67 for battery, IP66 for inverter, IP55 for cabinet
- Advanced fault detection and response

Intelligent Design

- Advanced energy management system
- VPP ready with SolaX Cloud (IEEE 2030.5, OpenADR)
- Supporting remote monitoring and maintenance
- Supporting a variety of C&I energy storage scenarios

Flexible Adaptability

- Grid-connected and off-grid support (with SolaX switching cabinet)
- Full-stack self-developed BMS, EMS, PCS & SolaXCloud
- One year of local historical data storage
- Cell-level balancing and smart temperature control

*V1.2. Information may be subject to modify without notice. 650.00098.00

	TRENE-P124B261L-E	TRENE-P125B261L-E
AC SIDE (ON-GRID)		
Rated AC power	124.9 kW	125 kW
Max. output apparent power	124.9 kVA	125 kVA
Rated AC current	189.3 A @220 V 181.1 A @230 V	189.4 A @220 V 181.2 A @230 V
Max. output continuous current	189.3 A@220 V 181.1 A@230 V	189.4 A@220 V 181.2 A@230 V
Rated AC voltage	3 / N / PE, 220 / 380 V 3 / N / PE, 230 / 400 V	
AC voltage range	340 ~ 440 V	
Rated AC frequency	50 Hz / 60 Hz	
Adjustable power factor range	-1 ~ +1	
THDi (rated power)	< 3%	
DC component	< 0.5% (rated power)	
AC SIDE (OFF-GRID)		
Rated AC output voltage	3 / N / PE, 220 / 380 V 3 / N / PE, 230 / 400 V	
Rated AC frequency	50 Hz / 60 Hz	
THDv (linear load)	< 3% (linear load)	
Unbalance load capacity (off-grid)	100%	
Overloading capacity	110%, long term; 120%, 1min	
Max. AC output continuous current	208.2 A @220 V 199.2 A @230 V	208.4 A @220 V 199.3 A @230 V
DC SIDE		
Battery type	LFP / 314 Ah	
Nominal energy	261 kWh	
Rated battery voltage	832 V	
Battery voltage range	650 ~ 936 V	
SYSTEM PARAMETE		
Dimensions (WxHxD)	1350 × 2355 × 1350 mm	
Weight	2810 kg	
Operating temperature range	-30 ~ 55°C (>45°C derating)	
Relative humidity	0 ~ 100% RH	
Max. operation altitude	3000 m	
Cooling concept	Liquid cooling	
Ingress protection	IP55	
Topology	Non-isolated	
Standards	IEC 62619, IEC 63056, IEC 62040, IEC 62477, IEC 61000, IEC 62933, UN 38.3, UL9540A	
Communication interface	Ethernet	
Communication protocol	Modbus TCP	
Anti-corrosion degree	C4 (C5 optional)	
Configuration of safety	Gas fire suppression + Water-based fire suppression + Ventilation + Explosion-proof plates	
Max. parallel quantity (off-grid)	10	

PCS

	X3-TRENE-124.9K	X3-TRENE-125K
AC SIDE (ON-GRID)		
Rated AC output power	124.9 kW	125 kW
Max. AC output apparent power	124.9 kVA	125 kVA
Rated AC output current	189.3 A @220 V 181.1 A @230 V	189.4 A @220 V 181.2 A @230 V
Max. AC output continuous current	189.3 A@220 V 181.1 A@230 V	189.4 A@220 V 181.2 A@230 V
Rated AC voltage	3 / N / PE, 220 / 380 V 3 / N / PE, 230 / 400 V	
AC voltage range	320 ~ 460 V	
Rated AC frequency	50 Hz / 60 Hz	
AC frequency range	50 ± 5 Hz / 60 ± 5 Hz	
Power factor range	-1~+1	
THDi (rated power)	< 3%	
DC component	< 0.5% (rated power)	
Unbalance load capacity (on-grid)	100%	
AC SIDE(OFF-GRID)		
Nominal AC voltage	3 / N / PE, 220 / 380 V 3 / N / PE, 230 / 400 V	
Rated AC frequency	50 Hz / 60 Hz	
THDv (linear load)	< 3% (linear load)	
Unbalance load capacity (off-grid)	100%	
Overloading capacity	110%, long term; 120%, 1min	
Max. AC output continuous current	208.2 A @220 V 199.2 A @230 V	208.4 A @220 V 199.3 A @230 V
DC SIDE		
Battery voltage range	650 ~ 936 V	
Max. charge / discharge current	202.1 A	202.3 A
GENERAL		
Max. efficiency	98.0%	
Ingress protection	IP66	
Operating temperature range	-35 ~ 60°C (>45°C derating)	
Max. operation altitude	3000 m	
Relative humidity	0 ~ 100% RH	
Dimensions (W × H × D)	310 × 665 × 880 mm	
Weight	95 kg	
Cooling concept	Smart air cooling	
Communication interface	RS485, CAN, Ethernet, DI	

PCS

	X3-TRENE-124.9K	X3-TRENE-125K
PROTECTION		
Protections	AC over / under voltage protection, DC component monitoring, AC input phase sequence error protection, Grid frequency high / low protection, Communication failure protection, Type II SPD on AC side, etc.	
STANDARD		
Certifications	CE, EN50549, VDE4105, G99, AS4777, CEI 0-21, IEC61727, PEA / MEA, NRS-097-2-1, RD1699, TOR	

PACK



	TB-HR522
Battery type	LFP 314 Ah
Battery capacity	52.2 kWh
Battery configuration	1P52S
Rated battery voltage	166.4 V
Battery voltage range	130 ~ 187.2 V
Weight	330 kg
Dimensions (W × H × D)	790 × 250 × 1140 mm
Charge / Discharge current	157 A
Relative humidity	0 ~ 95% RH (non-condensing)
Max. operation altitude	3000 m
Ingress protection	IP67
Communication	CAN

If there is any change in product size and parameters, please refer to the latest information without prior notice.

Liquid Cooling Energy Storage System

TRENE-P500B1044L-2H

249kW / 250kW / 260kW / 319kW / 399kW / 499kW / 500kW



*Configurable backup duration: 2-4 hours

High Performance

- All-in-one design, maximum 5 units in parallel
- High density design reduce 20%+ space and construction demands
- Pre-assembled products for rapid installation
- Factory pre-commissioning saving 50%+ time

Robust Reliability

- Full-stack self-developed 3S (PCS, EMS, BMS) enables stable operation
- IP66 (IP55 for cabinet) and C4/C5 anti-corrosion protection handle harsh conditions
- Smart Liquid cooling control ensures $\leq 3^{\circ}\text{C}$ uniformity, battery lifecycle +10%

Ultimate Safety

- 4-layer real-time monitoring for full-link risk control
- Cell-to-system level safety protection with aerosol firefighting
- Cabinet-level flame retardant design

Worry-free O&M

- Remote OTA for one-click updates on SolaXCloud
- Intelligent BMS management with 10ms-level data monitoring
- Rapid maintenance with 1-hour part replacement

*V1.0. Information may be subject to modify without notice. 650.00112.00

	TRENE - P500B1044L-2H	TRENE - P499B1044L-2H	TRENE - P399B1044L-2.5H	TRENE - P319B1044L-3H	TRENE - P260B1044L-4H	TRENE - P250B1044L-4H	TRENE - P249B1044L-4H
AC SIDE (ON-GRID)							
Rated AC power	500 kW	499.6 kW	399.6 kW	319.6 kW	260 kW	250 kW	249 kW
Max. output apparent power	500 kVA	499.6 kVA	399.6 kVA	319.6 kVA	260 kVA	250 kVA	249 kVA
Rated AC current	724.8 A@230 V 757.6 A@220 V	724.4 A@230 V 757.2 A@220 V	579.2 A@230 V 605.6 A@220 V	463.2 A@230 V 484.4 A@220 V	377.2 A@230 V 394 A@220 V	362.4 A@230 V 378.8 A@220 V	361.2 A@230 V 377.6 A@220 V
Max. output continuous current	724.8 A@230 V 757.6 A@220 V	724.4 A@230 V 757.2 A@220 V	579.2 A@230 V 605.6 A@220 V	463.2 A@230 V 484.4 A@220 V	377.2 A@230 V 394 A@220 V	362.4 A@230 V 378.8 A@220 V	361.2 A@230 V 377.6 A@220 V
Rated AC voltage	3 / N / PE, 230 / 400 V 3 / N / PE, 220 / 380 V						
AC voltage range	340 ~ 440 V						
Rated AC frequency	50 Hz / 60 Hz						
Adjustable power factor range	-1 ~ +1						
THDi (rated power)	< 3% (Rated power)						
DC Component	< 0.5% (Rated power)						
AC SIDE (OFF-GRID)							
Rated AC output voltage	3 / N / PE, 230 / 400 V 3 / N / PE, 220 / 380 V						
Rated AC frequency	50 Hz / 60 Hz						
THDv (linear load)	< 3% (Linear load)						
Unbalance load capacity (off-grid)	100%						
Overloading capability	110%, long term; 120%, 1min						
Max. AC output continuous current	797.2 A@230 V 833.6 A@220 V	796.8 A@230 V 832.8 A@220 V	637.2 A@230 V 666 A@220 V	509.6 A@230 V 532.8 A@220 V	414.8 A@230 V 433.6 A@220 V	398.8 A@230 V 416.8 A@220 V	397.2 A@230 V 415.2 A@220 V
DC SIDE							
Battery type	LFP / 314 Ah						
Battery capacity	1044 kWh						
Rated battery voltage	832 V						
Battery voltage range	689 - 936 V						
SYSTEM PARAMETER							
Dimensions (WxHxD)	2991 x 2896 x 2438 mm						
Weight	13 t						
Operating temperature range	-30 ~ 55°C (> 45°C derating)						
Relative humidity	0 ~ 100% RH						
Max. operating altitude	3000 m						
Cooling concept	Liquid cooling						
Ingress protection	IP55						
Topology	Non-isolated						
Standards	IEC 62619, IEC 63056, IEC 62040, IEC 62477, IEC 61000, IEC 62933, UN 38.3, UL9540A						
Communication interfaces	Ethernet						
Communication protocol	Modbus TCP						
Anti-corrosion degree	C5						
Configuration of safety	Gas fire suppression + Water-based fire suppression + Ventilation + (Optional Explosion-proof plates)						



AC Switching Cabinet

NEXUS ZERO

Nexus Zero

SYSTEM PARAMETERS					
Model	ZERO-125	ZERO-250	ZERO-500	ZERO-750	ZERO-1250
Rated AC voltage	3 / N / PE ,230 / 400 V 3 / N / PE ,220 / 380 V				
Rated AC frequency	50 Hz / 60 Hz				
Rated AC current@230V	181.2 A	362.3 A	724.6 A	1087 A	1811.6 A
Rated AC current@220V	189.4 A	378.8 A	757.6 A	1136 A	1893.9 A
Disruption time of backup switch ^①	0 ms				
Power limit (grid)	Yes				
Grid breaker	250 A	500 A	1000 A	1600 A	2500 A
AC out breaker	250 A	500 A	1000 A	1600 A	2500 A
Bypass breaker	250 A	500 A	1000 A	1600 A	2500 A
Ingress protection	IP55				
SPD	Type II				
Operating temperature	-30 to +55 °C				
Altitude	3000 m				
Dimension (W x H x D)	900 x 1600 x 800 mm	900 x 1600 x 800 mm	1200 x 2300 x 800 mm	1200 x 2300 x 800 mm	1900 x 2300 x 1200 mm
Weight (kg)	300 kg	330 kg	660 kg	730 kg	1500 kg
Rated short circuit current	10 kA	15 kA	30 kA	40 kA	60 kA
Certificates and approvals	EN/IEC61439-1, EN/IEC61439-2, EN/IEC61000				

①Test conditions: In the open-circuit state of the power grid, the total rated power of all Power Conversion Systems (PCS) is higher than the total power of the backup loads.

Block Diagram

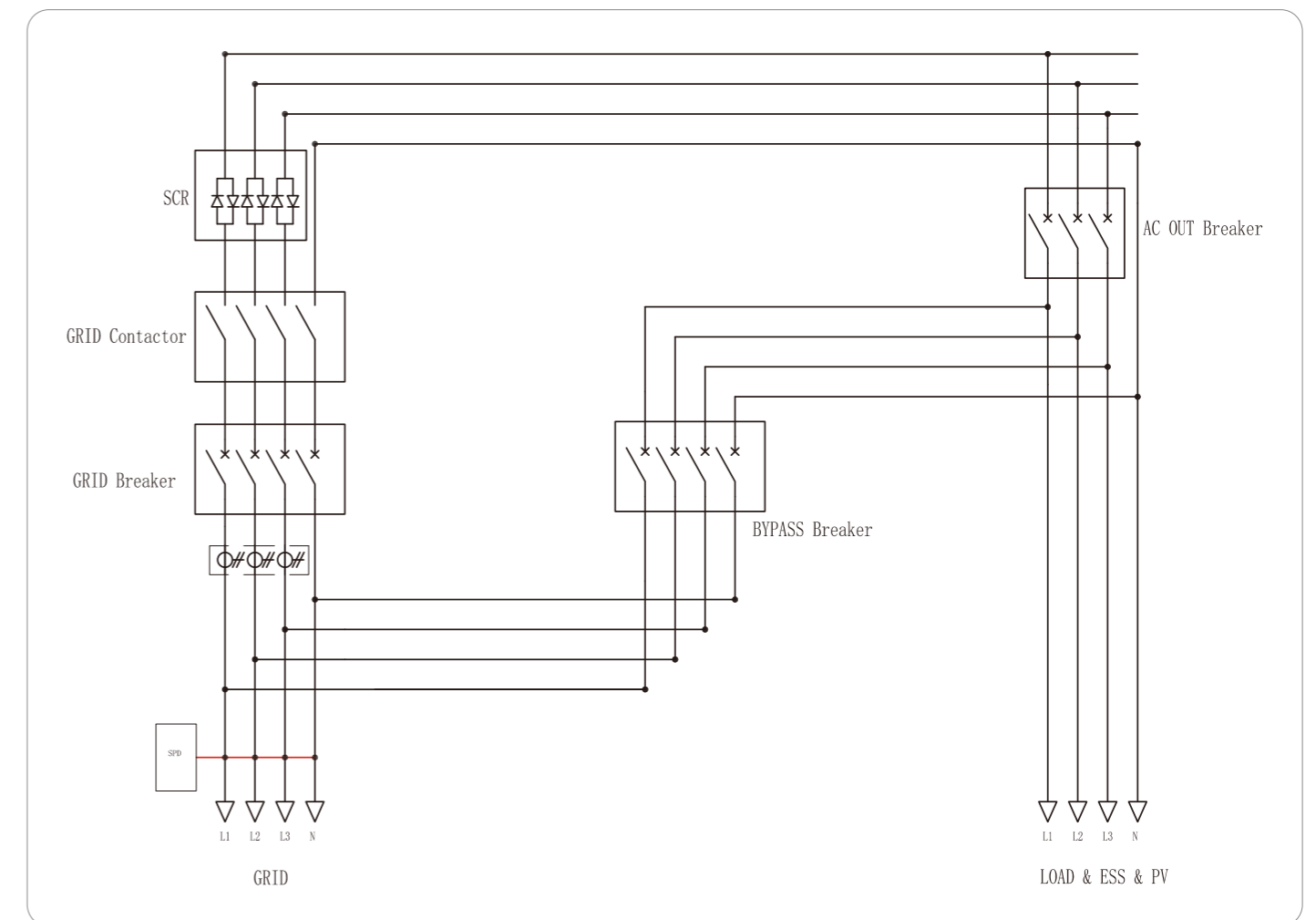

Intelligent Operation

- Seamless switching between grid and off-grid
- EMS 1000 PRO Inside: Seamlessly integrated, intelligent management of PV, ESS, and loads for optimal energy performance
- Supports a maximum switching power of up to 1.25MW

Safer and Reliable

- Load-friendly design, protects equipment from unstable grid damage
- Supports Type II surge protection
- Supports water ingress alerts, over-temperature warnings, and door lock status feedback

Environmental Adaptability

- IP55 protection rating, suitable for both indoor and outdoor use
- Supports operation in environments ranging from -30°C to 55°C
- Reliable operation at 3000 meters without derating
- C5-M corrosion protection standards for reliable performance in the harshest environments

Versatile Applications

- Supports connection to diesel generators to ensure stable energy supply
- Intelligent operation, supports multiple operation modes
- Supports building on-grid/off-grid, solar-storage microgrid, and solar-storage-diesel microgrid solutions



EMS1000 PRO



EMS1000 PRO BOX

EMS1000 PRO	
SOLAXCLOUD COMMUNICATION	
WAN	NET4, 10 M / 100 M / 1000 M
4G	CAT4
SIM card size	Nano - 4 FF, 12.3 x 8.8 mm; Class C, 1.8 V
Sample rate	Per 10 seconds, 2G data package
COMMUNICATION PORTS	
LAN	NET1 / NET2 / NET3, 10M / 100M / 1000M
RS485	RS485 x 8
CAN	CAN-FD x 2, CAN-2.0 x 1
Digital inputs	DI1-DI12, dry contact; DI13-DI18, wet contact
Digital outputs	DO x 8
Analog input	AI x 4
USB	USB2.0 x 2
ENVIRONMENT LIMIT	
Operating temperature	-40 ~ 60°C
Relative humidity	5 ~ 95% RH (non-condensing)
Max. operating altitude	3000 m
Ingress protection	IP20
POWER SUPPLY	
DC input voltage	DC 12 ~ 24 V
DC input current	0.65 A avg (1.17 A peak)
Power consumption	15.6 W avg (28 W peak)
MECHANICAL DATA	
Dimensions (W x H x D)	232 x 113.2 x 59 mm
Net weight	1400 g
Installation method	DIN-rail mounting, Wall mounting
CERTIFICATES AND APPROVALS	
Certificates and approvals	CE, RCM, SRRC

Smart & Flexible Features

- RS485, Ethernet, and 4G Support
- Up to 120 inverters connection
- Master-Slave device management (Up to 10 slave devices)
- Built-in web interface for local and remote monitoring

Efficiency & Simplicity

- Automatic inverter address search and assignment
- Auto-detection of EMS PRO slave devices
- Remote parameter configuration and system power adjustment support

Stability & Reliability

- Offline data transmission resumption and data loss prevention
- Industrial-grade reliability for high stability

EMS1000 PRO BOX-8

EMS1000 PRO BOX-16

SOLAXCLOUD COMMUNICATION		
WAN	NET4, 10 / 100 / 1000 Mbps	NET4, 10 / 100 / 1000 Mbps
4G	CAT4	CAT4
SIM card size	Nano - 4FF, 12.3 x 8.8 mm; Class C, 1.8 V	Nano - 4FF, 12.3 x 8.8 mm; Class C, 1.8 V
Sample rate	Per 10 seconds, 2G Data Package	Per 10 seconds, 2G Data Package
COMMUNICATION PORTS		
LAN	LAN x 7, 10 / 100 / 1000 Mbps	LAN x 15, 10 / 100 / 1000 Mbps
WAN	NET2, 10 / 100 / 1000 Mbps	NET2, 10 / 100 / 1000 Mbps
RS485	RS485 x 8	RS485 x 8
Digital Inputs	DI1 ~ DI12, dry contact; DI13 ~ DI18, wet contact	DI1 ~ DI12, dry contact; DI13 ~ DI18, wet contact
Digital Outputs	DO x 8	DO x 8
Analog Input	AI x 4	AI x 4
ENVIRONMENT LIMIT		
Operating Temperature	-30 ~ 55°C	-30 ~ 55°C
Relative humidity	5 ~ 95% RH (non-condensing)	5 ~ 95% RH (non-condensing)
Max. operating altitude	3000 m	3000 m
Degree of protection	IP54	IP54
POWER SUPPLY		
AC Input Voltage	100 ~ 240 V; 50 Hz / 60 Hz	100 ~ 240 V; 50 Hz / 60 Hz
Power Consumption	34.6 W Max	39.0 W Max
MECHANICAL DATA		
Dimensions (W x D x H)	450 x 283 x 177 mm	450 x 283 x 177 mm
Weight	5.3 kg	5.3 kg
Installation Method	Wall Mounting	Wall Mounting
CERTIFICATES AND APPROVALS		
Compliance	CE, RCM, SRRC	CE, RCM, SRRC

EMS1000



The Solax EMS1000 is designed for use in industrial and commercial energy storage and solar power stations.



Smart and Friendly

- Supports fault recording and second-level fault data retrieval
- Supports multi-device parallel energy control and intelligent output control
- Supports second-level data collection and local storage for up to 1 year



Efficient O&M

- Built-in web interface
- Supports local monitoring and remote access
- Supports cell-level data collection and monitoring

EMS1000

SOLAXCLOUD COMMUNICATION	
WAN	NET4, 10M / 100M / 1000M
4G	CAT4
SIM Card Size	Nano - 4FF, 12.3 mm × 8.8 mm; Class C, 1.8V
Sample Rate	Per 10 seconds, 2G Data Package
COMMUNICATION PORTS	
LAN	NET1 / NET2 / NET3, 10M / 100M / 1000M
RS485	RS485 × 8
CAN	CAN-FD × 2, CAN-2.0 × 1
Digital Inputs	DI1–DI12, dry contact; DI13–DI18, wet contact
Digital Outputs	DO × 8
Analog Input	AI × 4
USB	USB2.0 × 2
AMBIENT CONDITIONS	
Operating Temperature [OC]	-40 ~ 60
Relative Air Humidity [%]	5 ~ 95 (non-condensing)
Elevation [m]	3000
Protection Class	IP20
POWER SUPPLY	
DC Input Voltage [V]	12 ~ 24
DC Output Current [A]	0.65A avg (1.17A peak)
Power Consumption [W]	15.6W avg (28W peak)
STORAGE DATA	
Local data storage period	1 Year ^①
MECHANICAL DATA	
Dimensions (W × H × D) [mm]	232 × 113.2 × 59
Weight [g]	1400
Installation Method	DIN-rail Mounting, Wall Mounting
COMPLIANCE	
Compliance	CE, RCM, SRRC

^① The local storage logic follows a loop-overwrite system with an average overwrite cycle period longer than one year. However, slight variations may occur depending on the user's actual usage scenarios.



SMART SOLAR, STORAGE & ENERGY SOLUTIONS
Utility Energy Storage

Liquid Cooling Energy Storage System

ORI-P2500B5015L-2H



High Efficiency

- Factory pre-assembly for rapid on-site installation
- Factory pre-commissioning saving 50%+ time
- Cluster-level management, +8% system available energy

Ultimate Safety

- Anti-condensation design for battery pack and container
- Advanced thermal and electrical isolation safeguards for secure operations and long-term ROI
- 4-Level breaking protection for full-link risk control

Robust Reliability

- 2-hour fire-rated cabinets for maximum safety assurance
- IP66 for PCS and C4 anti-corrosion protection handle harsh conditions
- Smart Liquid cooling control ensures $\leq 3^{\circ}\text{C}$ uniformity, battery lifecycle+10%

Worry-free O&M

- Intelligent BMS management with 10ms-level data monitoring
- Rapid maintenance with 1-hour part replacement
- Smart controller for one-click system upgrade

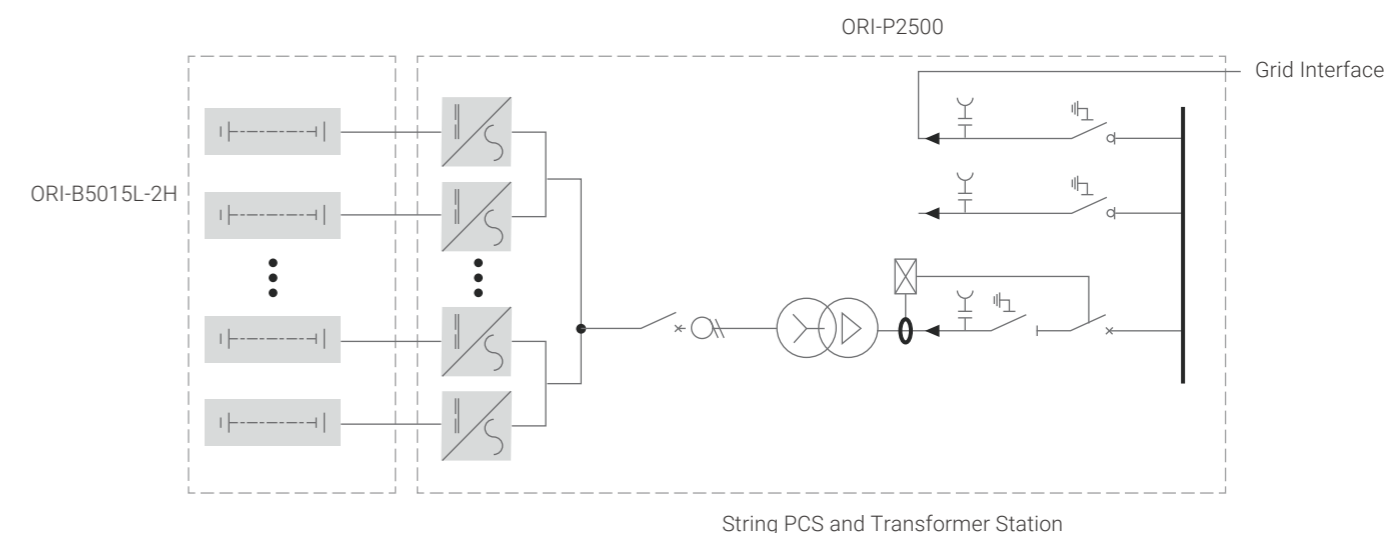

2/4-hour energy storage solution :

One ORI-P2500 can be paired with 1/2 unit of ORI-B5015L-2H to form a 2H/4H BESS

Liquid Cooling Battery Energy Storage System



ORI-B5015L-2H

DC SIDE	
DC rated voltage	1331.2 V
DC voltage range	1123.2 ~ 1497.6 V
Pack structure	1P416S × 12
Cell type	LFP 314 Ah / 3.2 V
Battery pack type	314 Ah / 332.8 V
Battery cluster type	314 Ah / 1331.2 V
Rated energy capacity	5015 kWh
GENERAL	
Cooling method	Liquid cooling
Operation temperature range	-30 ~ 50°C
Storage temperature range	-30 ~ 60°C
Operation humidity range	≤ 100% RH (non-condensing)
Charge & discharge rate	0.5 P
Max. operating altitude	≤ 4000 m
Dimensions (W × H × D)	6058 × 2896 × 2438 mm
Container weight	≤ 43 t
Protection level	IP55 C4 (optional C5)
Configuration of safety	Gas fire suppression + Water-based fire suppression + Ventilation (optional explosion-proof plates)
Communication interface	RS485, Ethernet, CAN
Communication protocol	Modbus TCP/RTU, IEC 104, IEC 61850
Certificates and approvals	IEC 62477, IEC 62619, IEC 63056, IEC 60730, IEC 62933, UL9540A, IEC61000, UN38.3

String PCS and Transformer Station



ORI-P2500

DC SIDE	
Max. DC voltage	1500 V
Rated DC power	215 kW × 12
DC voltage range	1000 ~ 1500 V
AC SIDE	
Rated AC power	2500 kVA
Rated AC voltage	6 ~ 35 kV
Rated AC frequency	50 Hz
THDi (rated power)	< 3%
Adjustable power factor range	-1 ~ +1
GENERAL	
Isolation method	Oil-immersed transformer
PCS maximum efficiency	99%
Ingress protection	IP66 (PCS) / IP54 (Cabinet body)
Operating temperature range	-30 ~ 50°C (derated above 45°C)
Relative humidity	≤ 100% RH (non-condensing)
Max. operating altitude	≤ 2000 m (optional: 4000m)
Communication interfaces	RS485 / CAN / Ethernet
Dimensions (W × H × D)	6058 × 2896 × 2438 mm
Container weight	≤ 16 t
Certificates and approvals	IEC61000, IEC 60076, IEC62271

Liquid Cooling Energy Storage System

ORI-P7500B15045L-2H ORI-P5000B10030L-2H



High Efficiency

- Factory pre-assembly for rapid on-site installation
- Factory pre-commissioning saving 50%+ time
- Cluster-level management, +8% system available energy

Ultimate Safety

- Anti-condensation design for battery pack and container
- Advanced thermal and electrical isolation safeguards for secure operations and long-term ROI
- 4-Level breaking protection for full-link risk control

Robust Reliability

- 2-hour fire-rated cabinets for maximum safety assurance
- IP66 for PCS and C4 anti-corrosion protection handle harsh conditions
- Smart Liquid cooling control ensures $\leq 3^{\circ}\text{C}$ uniformity, battery lifecycle+10%

Worry-free O&M

- Intelligent BMS management with 10ms-level data monitoring
- Rapid maintenance with 1-hour part replacement
- Smart controller for one-click system upgrade

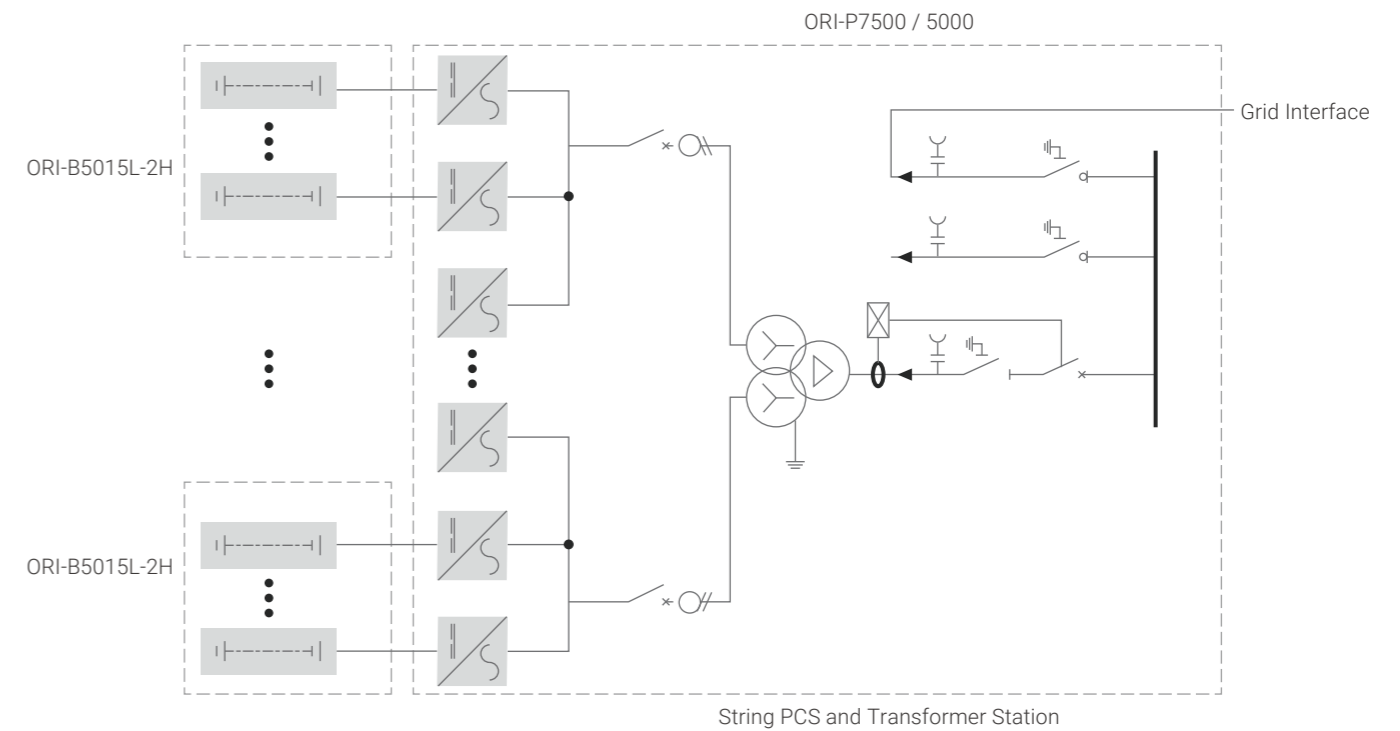

2/4-hour energy storage solution:

One ORI-P5000 can be paired with 2/4 unit of ORI-B5015L-2H to form a 2H/4H BESS

One ORI-P7500 can be paired with 3/6 unit of ORI-B5015L-2H to form a 2H/4H BESS

Liquid Cooling Battery Energy Storage System



ORI-B5015L-2H

DC SIDE	
DC rated voltage	1331.2 V
DC voltage range	1123.2 ~ 1497.6 V
Pack composition	1P416S x 12
Cell type	LFP 314 Ah / 3.2 V
Battery pack type	314 Ah / 332.8 V
Battery cluster type	314 Ah / 1331.2 V
Rated energy capacity	5015 kWh
GENERAL	
Cooling method	Liquid cooling
Operation temperature range	-30 ~ 50°C
Storage temperature range	-30 ~ 60°C
Operation humidity range	≤ 100% RH (non-condensing)
Charge & discharge rate	0.5 P
Max. operating altitude	≤ 4000 m
Dimensions (W x H x D)	6058 x 2896 x 2438 mm
Container weight	≤ 43 t
Protection level	IP55 C4 (optional C5)
Configuration of safety	Gas fire suppression + Water-based fire suppression + Ventilation (optional explosion-proof plates)
Communication interface	RS485, Ethernet, CAN
Communication protocol	Modbus TCP/RTU, IEC 104, IEC 61850
Certificates and approvals	IEC 62477, IEC 62619, IEC 63056, IEC 60730, IEC 62933, UL9540A, IEC61000, UN38.3

String PCS and Transformer Station



ORI-P7500

ORI-P5000

DC SIDE		
Max. DC voltage	1500 V	
Rated DC power	215 kW x 36	215 kW x 24
DC voltage range	1000 ~ 1500 V	
AC SIDE		
Rated AC power	7500 kVA	5000 kVA
Rated AC voltage	10 ~ 35 kV	
Rated AC frequency	50 Hz	
THDi (rated power)	< 3%	
Adjustable power factor range	-1 ~ +1	
GENERAL		
Isolation method	Oil-immersed transformer	
PCS maximum efficiency	99%	
Ingress protection	IP66 (PCS) / IP54 (Cabinet body)	
Operating temperature range	-30 ~ 50°C(derated above 45°C)	
Relative humidity	≤ 100% RH (non-condensing)	
Max. operating altitude	≤ 2000 m (optional: 4000m)	
Communication interfaces	RS485 / CAN / Ethernet	
Dimensions (W x H x D)	12192 x 2896 x 2438 mm	
Container weight	≤ 34.5 t	≤ 29.5 t
Certificates and approvals	IEC61000, IEC 60076, IEC62271	

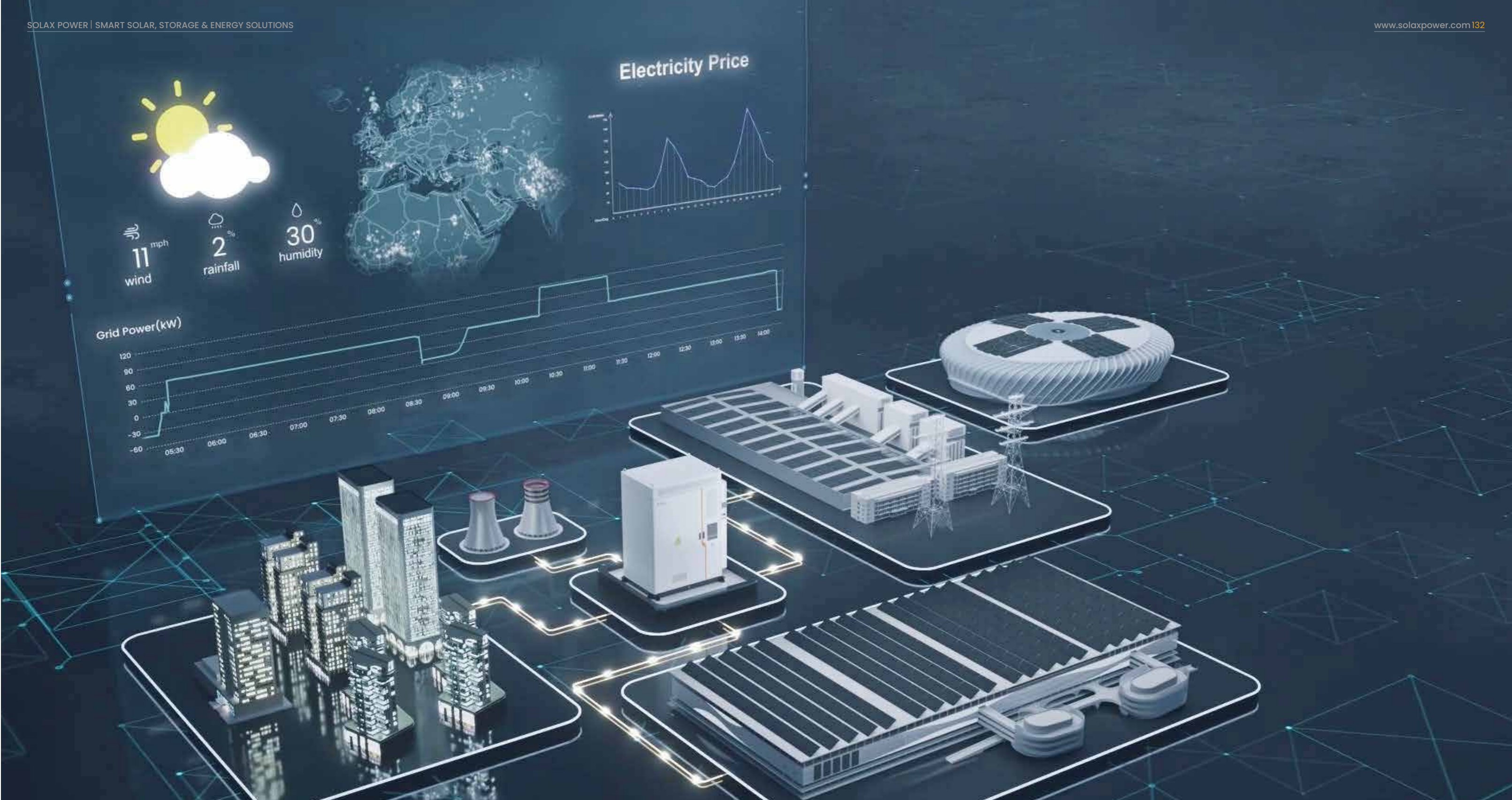

SMART SOLAR, STORAGE & ENERGY SOLUTIONS
Smart Energy Management

Remote Monitoring Around The Clock

SolaXCloud Monitoring

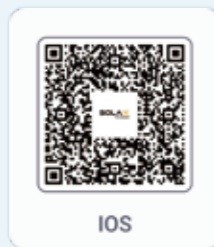

IOS

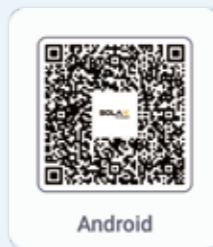

Android



Google Play

XHub



XCORE & XCOPILOT

Product Manual / Installation Guide
/ Q&A / After-sales Questions
/ Power Consumption Data



SolaX Design 2.0

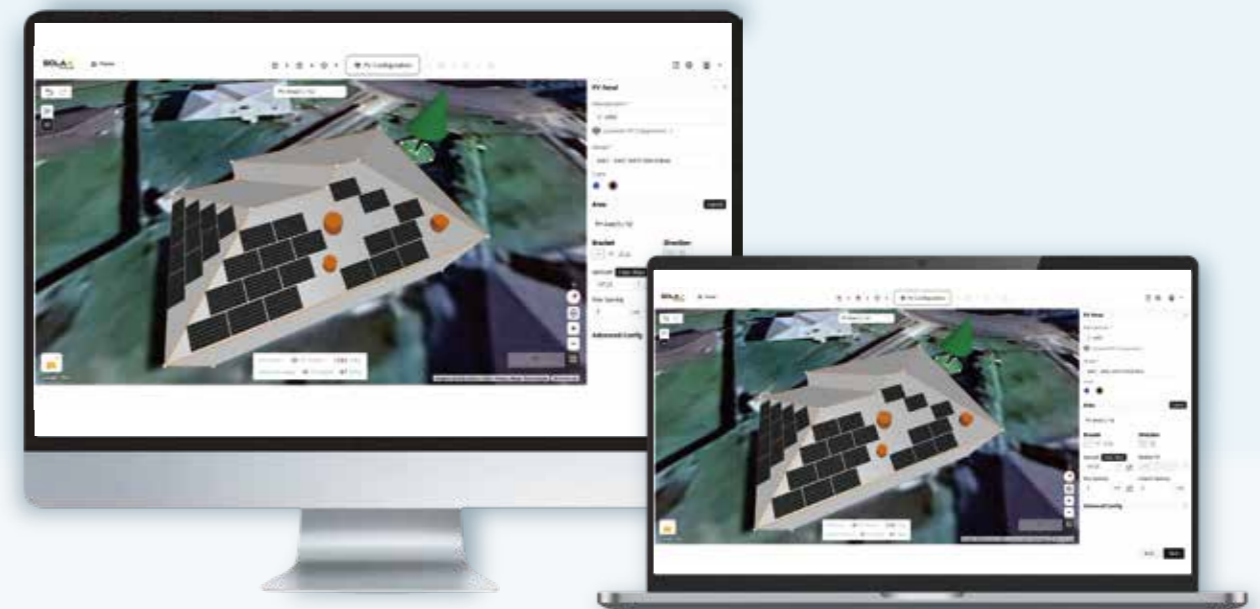

Pocket WiFi v4.0



Pocket WiFi + LAN V2.0



Pocket 4G V3.0

Pocket WiFi V4.0



Feature

- Faster, more stable device connections
- Auto-caches data locally during disconnection: no data loss
- Supports Bluetooth/AP dual modes for seamless networking
- Smart grid integration for real-time energy management
- Real-time response with ultra-precise data
- 25% smaller than WiFi V3.0; sleeker and more portable
- 30% longer transmission distance vs. WiFi V3.0 with strong penetration
- Intuitive interface reduces misoperations

Pocket WiFi

Model	Pocket WiFi V4.0
Power supply	5V 50mA DC
Wireless module	WiFi 6, 2.4 GHz
Antenna gain	0.5 dBi
Data transfer interval	5 mins / 10s optional
Dimensions	83 x 44 x 26.5 mm
Weight	45 ± 10 g
Degree of protection	IP65
Operating temperature range	-35 ~ +60°C

Pocket WiFi+LAN V2.0



Feature

- Easily connect devices using Bluetooth for a hassle-free setup experience
- Ensure a stable and high-speed connection via Ethernet.
- Quick and easy installation with Plug and Play
- Maintain data transmission for up to 30 days without a network
- Smaller size for an elegant and coordinated look
- Physical buttons for easy reboot, reset, and AP mode activation
- Self-diagnosis capabilities for easy troubleshooting

Pocket LAN

Model	Pocket WiFi+LAN V2.0
Power supply	5V 200mA DC
Wireless module	WiFi 2.4 GHz
Ethernet	10/100 M
Antenna gain	0.86 dBi
Data transfer interval	5 mins / 10s optional
Dimensions	134 x 44 x 26.5 mm
Weight	80 ± 10 g
Degree of protection	IP65
Operating temperature range	-35 ~ +60°C

Pocket 4G V3.0



Feature

- Quick installation with "Plug & Play" function
- IP 65 dust prevention water proofing designs
- Stable data transmission and good reliability
- Offline data storage and resuming
- Multi-communication operator support

Pocket 4G

Model	Pocket 4G V3.0
Power Supply	5V 500mA DC
SIM Card Size	Nano - 4FF 12.3*8.8 mm
Support Band	LTE-FDD: B1/B3/B5/B7/B8/B20/B28 LTE-TDD: B38/B40/B41 GSM: 850/900/1800/1900MHz
Data Transfer Interval	5 mins
Dimensions	112*45.7*28.5 mm
Weight	135g
Degree of Protection	IP65
Operating Temperature Range	-35°C ~ +75°C



XHub

AI-Powered Management System

- Unified Dispatching of PV, Energy Storage, EV Chargers, Heat Pump, and Electrical devices.
- AI forecasts power gen/use, dynamically boost earnings

Third-Party Ecosystem

- Compatible with EEBUS, SGready, Modbus, etc., Integrate Shelly devices – exceptional compatibility and powerful connectivity at your fingertips

Multi-Scenario Interconnected

- High-power loads intelligently dispatched by priority
- Pre-charge energy before outages or severe weather
- Smartly adjust grid import limits to reduce demand charges

Grid-Friendly

- Supports §14a EnWG&§9 EEG, Ripple Control, DRM, 3-Phase Unbalanced Output – engineered for effortless compliance with grid regulations

XHub

POWER SUPPLY

AC input voltage	1P2W: 100 ~ 240 V, 50 Hz / 60 Hz; 3P4W: 100 ~ 240 V, 50 Hz / 60 Hz;
Power consumption	5 W typical (8 W peak)

INTERFACE

LAN	10 / 100 Mbps
ETH	10 / 100 Mbps
WiFi	802.11 b / g / n (2.412 GHz ~ 2.484 GHz)
Bluetooth	BLE 5.1 (2.402 ~ 2.480 GHz)
RS485	RS485 x 2
Digital inputs	DI x 4
Digital outputs	DO x 4
Analog input	AI x 2

INTERACTION

LED	LED Indicator x 3 (RUN, ALM, COM)
Button	RST
APP	SolaXCloud

MEASUREMENT RANGE

Current range	Direct connection: < 80 A, External CT: > 80 A
Voltage range	1P2W (L-N): 100~300 V; 3P4W (L-N): 100~300 V
Energy accuracy	±1 %

ENVIRONMENT LIMIT

Operating temperature range	-20 ~ 60 °C
Relative humidity	5 % ~ 95 % RH(non-condensing)
Max. operation altitude	3000 m
Ingress protection	IP20

GENERAL

Dimensions (W x H x D)	126 mm x 100 mm x 65 mm
Installation type	DIN - rail Mounting
Net weight	600 g

COMPLIANCE

Compliance	CE, RCM, PSTI
------------	---------------

Accessories



M1-40



M3-40



M3-40-Dual

Plug-and-play CT solution for easy installation

50ms high refresh rate for more precise and faster control

Intelligent phase sequence and CT direction adjustment, automatically resolving installation issues

Supports remote settings via SolaX Cloud APP

Separates strong and weak currents for enhanced security

Capable of monitoring power from both the grid and third-party inverters simultaneously*

* supported only by the two-circuit model: M3-40-Dual

Solutions

M3-40
Networking through RS485 cable

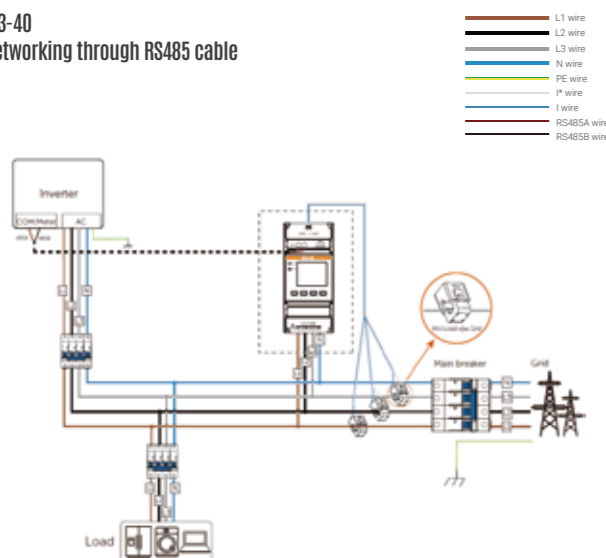

M3-40
Wireless data transmission through Wi-BR

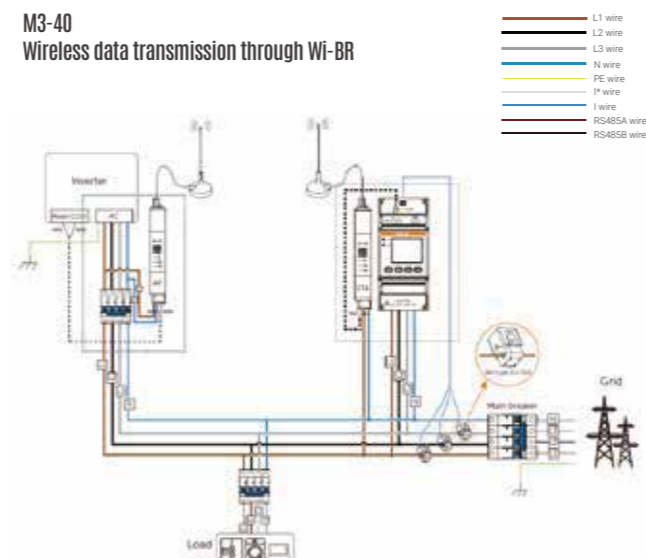

*V1.4. Information may be subject to modify without notice. 650.00079.00

	M1-40	M3-40	M3-40-Dual
Power grid type	1P2W	3P3W / 3P4W	
Rated voltage	220 V ~ 240 V	3 × 220 / 380 V ~ 3 × 240 / 415 V	3 × 57.7 / 100 V ~ 3 × 240 / 415 V
Operating voltage	100 V ~ 288 V	100 V ~ 280 V	50 V ~ 480 V
Current	*A / 40 mA		
Recommended CT specification	100 A / 40 mA, 200 A / 40 mA, 400 A / 40 mA, 600 A / 40 mA		
Recommended rogowski coil specification	1000 A / 40 mA		
Power consumption	< 1.2 W	< 1.5 W	< 1.2 W
Measurement accuracy class	Voltage and current: Class 0.5 Active power: Class 1 Reactive power: Class 2		
Resolution requirement	Active power: 0.1 W Frequency: 0.001 Hz		
Frequency	45 Hz ~ 65 Hz		
Frequency tolerance	0.01 Hz		
Operating temperature	-40°C ~ 70°C		
Operating humidity	≤ 95% RH (non-condensing)		
Operating altitude	< 4000 m		
Degree of protection	IP20		
Dimensions (W x H x D)	18 mm × 100 mm × 65.5 mm	45 mm × 100 mm × 65.5 mm	72 mm × 100 mm × 65.5 mm

	SCT-16 Split Core 100A/40mA	SCT-16 Split Core 100A/40mA(3in1)	SCT-24 Split Core 200A/40mA(3in1)	SCT-36 Split Core 400A/40mA(3in1)	SCT-50 Split Core 600A/40mA(3in1)
Frequency	50 / 60 Hz				
Rated current	100 A	100 A	200 A	400 A	600 A
Rated output	40 mA (AC)				
Inner Diameter	16mm	16mm	24mm	36mm	50mm
Secondary load	20 Ω				
Accuracy	Class 0.5				
Transformation ratio	2500:1	2500:1	5000:1	10000:1	15000:1
Installation	Split-Core				
Altitude	≤ 4000 m				
Operating temperature	-40 °C ~ 85 °C		-40 °C ~ 70 °C		
Operating humidity	≤ 95%		≤ 70%		
Dielectric strength	3 kV / 1 mA / 1 min				
Insulation resistance	500 MΩ / 500 Vdc				
Case material	PA / UL 94-V0				
Bobbin	PBT / UL 94-V0				
Core	Ferrite				
Enameled wire	Copper				
Leads	UL 1581, 24 AWG				
Certification	CE, UL, RoHS, REACH				
Line length	2 m				

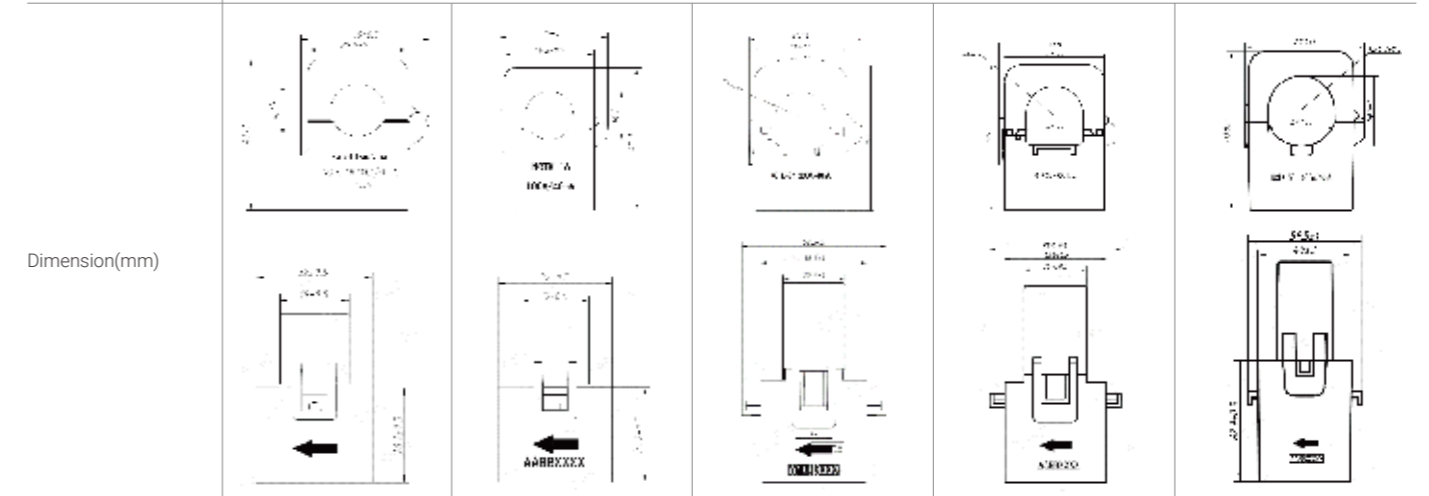

Accessories



Wireless Bridge

Wi-BR

Wide Coverage

- Efficient and stable data transmission up to 200m

Strong Penetration

- Penetration ability up to 4 floors (about 30 meters vertically)

Intelligent Design

- DIN-rail installation for 85-277V AC power supply

Flexible Adaptability

- Compatible with single & three-phase meters

* Wireless communication may be affected by obstacles in complex environments, reducing transmission distance. Lab data shows that it can reach up to 200 meters horizontally in open spaces. However, with walls blocking the signal, installation distance should be reduced, supporting up to 4 layers of partition walls (about 30 meters vertically)

Wi-BR

Working method	AP / STA
Protocol	IEEE 802.11ah
Communication terminal	RS485 * 1 (for each model)
Phase voltage	85 ~ 277 Vac
Max. power consumption	2 W
Operating temperature	-25 ~ 55°C
Dimensions	18 × 98 × 66 mm
Mounting type	DIN rail
Ingress protection rating	IP20
Altitude	≤ 2000 m

Comparison of the performance of four methods across different communication aspects

The following data is obtained through actual testing using inverter equipped with electricity meter in Solax laboratory. The actual on-site transmission distance may vary depending on the installation environment.

Security	SolaX	Wi-Fi	LORA	Zigbee
Performance	Best	Best	Poor	Good

Anti-interference	SolaX	Wi-Fi	LORA	Zigbee
Performance	Best	Best	Poor	Good

Transmission capability	SolaX	Wi-Fi4/5/6	LORA	Zigbee
Transmission distance	200m	100m	130m	20m

*The test data was obtained in an open area without any barriers.

Signal penetration ^①	SolaX	Wi-Fi	LORA	Zigbee
Number of floor ^②	4	1	3	1

*The results were obtained under test conditions of penetrating 120 cm thick reinforced concrete, with a floor-to-floor spacing of 4.5 meters.

① The wall-penetration test is an independent scenario, and its data does not affect or interact with the open-space scenario data
 ② The complete functions of the inverter can work properly through control across this number of floors

Installation

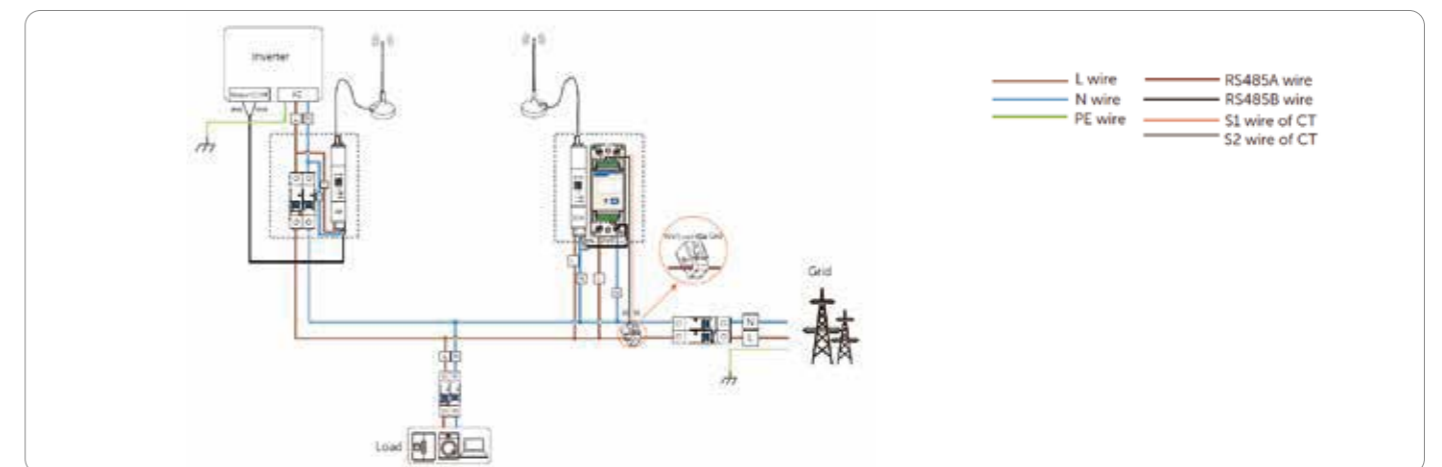

*The product images are for illustration only and may have slight differences from the actual product



SMART SOLAR, STORAGE & ENERGY SOLUTIONS
EV Charger

EV Charger



SMART EV CHARGER

X1-EVC
7.2kW

X3-EVC
11kW / 22kW

High Efficiency

- Capable of 100% green energy
- Maximizes surplus green energy utilization in a zero-export system

Assured Safety

- Current leakage protection (30mA AC & 6mA DC)
- Smart dynamic load balance control

Intelligent Design

- Smart RFID management function
- Smart APP remote control

Flexible Adaptability

- Selectable plug or socket outlet
- Easy indoor and outdoor installation

*V1.3. Information may be subject to modify without notice. 650.00043.00

	X1-EVC-7.2K	X3-EVC-11K	X3-EVC-22K
AC NOMINAL INPUT			
Phases/Lines	Single phase	Three phase	Three phase
Voltage	1 / N / PE, 230 V	3 / N / PE, 230 / 400 V	3/N/PE, 230 / 400 V
Frequency	50 ± 5 Hz / 60 ± 5 Hz	50 ± 5 Hz / 60 ± 5 Hz	50 ± 5 Hz / 60 ± 5 Hz
AC NOMINAL OUTPUT			
Voltage	1 / N / PE, 230 V	3 / N / PE, 230 / 400 V	3 / N / PE, 230 / 400 V
Current	32 A	16 A	32 A
Power	7.2 kW	11 kW	22 kW
INTERFACE			
Wireless module		Wi-Fi 2.4GHz	
Ethernet		10 / 100 M	
RS485		Yes	
RFID		Yes	
Ocpp 1.6 (JSON)		Yes	
LCD screen		Optional	
CT clamps	X1	X3	X3
GENERAL DATA			
Housing material	Plastic / Metal		
Installation method	Wall-mount / Pedestal-mount (Optional)		
Wall-mount bracket	Yes		
Charging outlet	Type P (Charging cable with plug) / Type S (Socket-outlet)		
Cable length	6.5 m (Type P)		
Operating temperature	-30 ~ 50°C		
Working humidity	5 ~ 95% RH (non-condensing)		
Working altitude	< 2000 m		
Degree of protection	IP65		
Impact resistant	IK10 (Housing) / IK08 (LCD screen)		
Application site	Indoor / Outdoor		
Cooling concept	Natural cooling		
Dimension (W × H × D)	249 × 370 × 155 mm (for type S) / 265 × 370 × 155 mm (for type P)		
Net weight	7 kg (for type S) / 10.5 kg (for type P)		
PROTECTION			
Multiple protection	Over/Under voltage protection, Overload protection, Shortcircuit protection, Current leakage protection, Grounding protection, Surge protection, Overtemperature protection		
Integral earth leakage protection	Integrated current failure monitoring (30mA AC & 6mA DC)		
Built-in pen fault technology ^①	According to BS 7671:2018 requirements		
Safety standard	IEC 61851-1:2017, IEC 62196-2:2016		
Encrypted communication	TLS		
Certification	CE, UKCA, LVD, EMC, RED		

① Only for chargers sold in the UK region

Solution

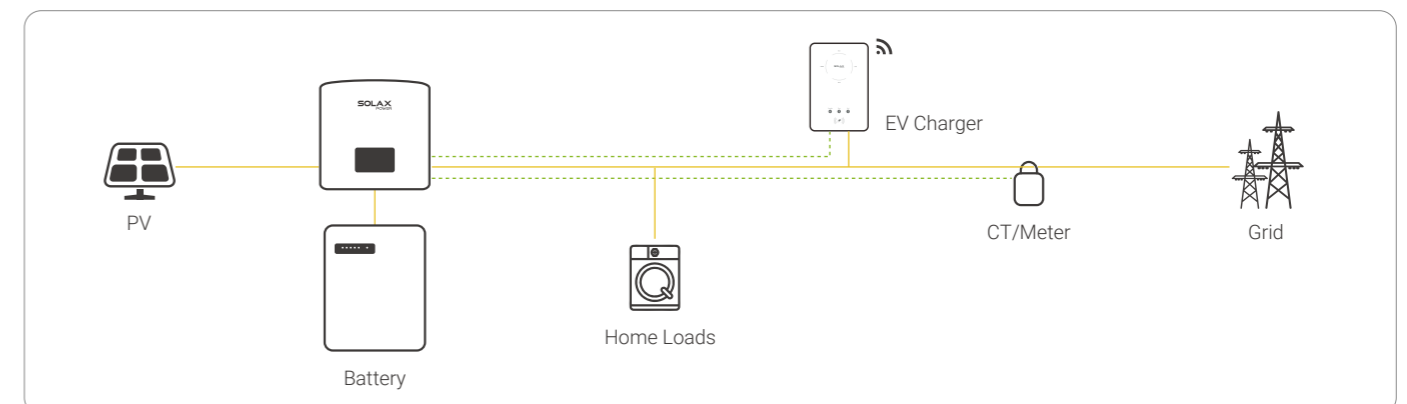

EV Charger



Smart EV Charger G2

X1-HAC-4 / X1-HAC-7
X3-HAC-11 / X3-HAC-22

High Efficiency

- Capable of 100% green energy
- Automatic switch between single and three phases
- Maximizing surplus green energy utilization in a zero-export system

Assured Safety

- Current leakage protection (30mA AC & 6mA DC)
- Smart dynamic load balance control

Intelligent Design

- Smart RFID management function
- Smart APP remote control

Flexible Adaptability

- Selectable plug or socket outlet
- Easy indoor and outdoor installation
- Supporting multiple communication protocols

Solutions

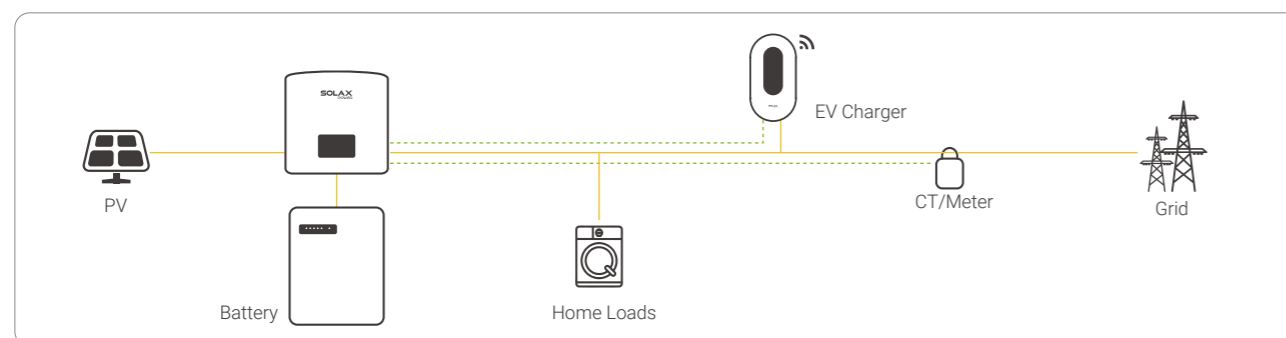

*V1.4 Information may be subject to modify without notice. 650.00067.00

	X1-HAC-4	X1-HAC-7	X3-HAC-11	X3-HAC-22
AC NOMINAL INPUT				
Voltage	230 V	230 V	400 V	400 V
Frequency	50 Hz / 60 Hz	50 Hz / 60 Hz	50 Hz / 60 Hz	50 Hz / 60 Hz
Grounding type	TN, TT, IT	TN, TT, IT	TN, TT, IT	TN, TT, IT
AC NOMINAL OUTPUT				
Voltage	230 V	230 V	400 V	400 V
Current	6-20 A (single phase)	6-32 A (single phase)	6-16 A (single phase or three phases)	6-32 A (single phase or three phases)
Power	1.4 ~ 4.6 kW	1.4 ~ 7.2 kW	1.4 ~ 11 kW	1.4 ~ 22 kW
INTERFACE & COMMUNICATION				
Communication interface	Wi-Fi / Ethernet / 4G (optional) / RS 485 × 2			
Protocol	OCPP 1.6j, Modbus TCP, Modbus RTU, Cloud API			
Communication	IEC 61851-1			
Authentication	Plug & Charge / RFID (ISO-14443-A) / APP			
MID meter	External (optional)			
HMI	RGB LED / APP / LCD (optional)			
Remote control	APP & Web			
Application	Residential / Destination place / Public			
GENERAL DATA				
Housing material	PC			
Installation method	Wall / Pedestal (optional)			
Charging outlet	Type2 plug / Type2 socket (IEC 62196)			
Cable length	6.5 m (Type P)			
Operation temperature	-30~50°C (without screen) / -25~50°C (with screen)			
Storage temperature	-40 ~ 60°C			
Operation humidity	5% ~ 95% RH (non-condensing)			
Max. operation altitude	2000 m			
Degree of protection	IP65 (plug type) / IP54 (socket type) IK10 (housing) / IK08 (screen)			
Cooling method	Natural cooling			
Application site	Indoor / Outdoor			
Weight	5 kg for plug type	3 kg for socket type 5 kg for plug type	3 kg for socket type 6.5 kg for plug type	3 kg for socket type 6.5 kg for plug type
Dimension (W × H × D)	206 × 390 × 139 mm			
PROTECTION				
Multiple protection	Over/Under voltage protection, Overload protection, Shortcircuit protection, Current leakage protection, Grounding protection, Surge protection, Overtemperature protection			
Theft protection	Support theft protection with a padlock			
Integral earth leakage protection	Integrated current failure monitoring (30 mA AC & 6 mA DC)			
Cable protection ^①	Cable lock (APP control)			
Relay protection	Relay weld detection			
Built-in PEN fault technology	According to BS 7671:2018 requirements ^②			
Standards	IEC 61851-1:2017, IEC 62196-2:2016			

① Only for socket type
② Only for chargers sold in the UK region



Fast DC Charger

High Efficiency

- Intelligently distribute charging power to meet the charging needs of different EVs.
- Support EMS intelligent dynamic power control, and form an integrated PV-ESS-EV Solution.

Intelligent Design

- Support OCPP1.6J protocol to access third-party operation platform.
- Support multiple network communication (Ethernet / Wi-Fi / 4G).
- Integrated smart HMI: 12.1-inch high-contrast LCD.

Assured Safety

- Safe and reliable, with multiple fault protection.
- Equipped with cable management system to enhance user experience.

Flexible Adaptability

- All-in-one design, easy and quick installation, compact and lightweight structure can be flexibly installed in various positions.
- The voltage range of 200-1000V is suitable for all current mainstream charging scenarios.

	FDC-120	FDC-180	FDC-240	FDC-300	FDC-360
AC NOMINAL INPUT					
Earthing system	TN-S / TT				
Voltage	400V ± 15%				
Current	185 A	277 A	369 A	461 A	553 A
Frequency	50 / 60Hz				
DC NOMINAL OUTPUT					
Voltage	200 V ~ 1000 V				
Current	Max.250 A (350 A optional)				
Power	120 kW	180 kW	240 kW	300 kW	360 kW
BASIC ATTRIBUTES					
Charge connector	Dual (CCS2 + CCS2)				
Cable length	5m (Including length of the charging connector)*				
Enclosure	Galvanized steel				
Installation method	Floor mounted				
INTERFACE & COMMUNICATION					
HMI	12.1-inch touch screen with shell				
Language	English (standard) other languages available by firmware upgrade				
Authentication	QR code / RFID card /Password login				
DC meter	CE certified DC meter standard equipped (MID meter optional)				
POS terminal	Optional				
Cable management system	Yes				
Communication interface	Ethernet / 4G / Wi-Fi				
Protocol	OCPP 1.6 J				
ELECTRICAL PARAMETER					
Efficiency	≥ 95% @Nominal output power				
Power factor	≥ 0.99 (50% load above)				
THDi	< 5%				
Standby self-consumption	≤100 W				
Ripple factor	≤ ±5%				
SAFETY					
RCD	Type A				
Emergency stop	Yes				
Enclosure ratings	IP54				
Impact protection	IK10 for shell, IK08 for screen				
Electrical protection	Over current, Under voltage, Residual current, Surge protection, Leakage protection, Short circuit, Over temperature, etc				
EVSE-vehicle protocol	DIN SPEC 70121,ISO 15118				
Certifications	CE / CB				
Certifications standard	IEC61851 2017, IEC 62196-1,IEC 62196-3, etc				
OPERATION ENVIRONMENT					
Cooling method	Air-cooling				
Noise	≤ 65 dB (A) @ 1 m / 25 °C				
Operation temperature	-25 ~55°C (Derating above ambient temperature 55°C)				
Working humidity	5 % ~ 95 % without condensation				
Working altitude	≤ 2000 m				
GENERAL					
Weight	400 kg	480 kg	530 kg	570 kg	610 kg
Dimensions (W × H × D)	750 × 2000 × 600 mm	750 × 2000 × 600 mm	830 × 2050 × 740 mm	830 × 2050 × 740 mm	830 × 2050 × 740 mm

*The cable length can be customized.



SMART SOLAR, STORAGE & ENERGY SOLUTIONS
Heat Pump

Air to Water Heat Pump



Solax Thermal R290 Series

High Performance

- Integrated with PV and ESS to maximize green energy self-consumption
- SCOP level: A+++
- Maximum leaving water temperature of 80°C

Flexibility

- Available in 5 capacity sizes (8 to 16 kW), suitable for renovations and large new buildings
- Highly interoperable, SG ready, Modbus TCP/RTU supported
- Heating + Cooling + Domestic Hot Water (DHW)

Eco-Friendly

- R290 natural refrigerant, low GWP and a low-carbon lifestyle
- Extremely quiet operation with low noise level

Intelligent Control

- Smart App control supports remote monitoring, operation, and OTA updates
- Brushless DC motor enables stepless speed regulation

*V1.2. Information may be subject to modification without notice. 650.00090.00

STU1-C08R290 STU1-C10R290 STU1-C12R290 STU1-C14R290 STU1-C16R290 STU3-C08R290 STU3-C10R290 STU3-C12R290 STU3-C14R290 STU3-C16R290

Power supply		220 ~ 240 V / 1N~ / 50 Hz					380 ~ 415 V / 3N~ / 50 Hz				
Heating (A: 7 / 6°C W: 30 / 35°C)	Capacity	8.5 kW	10 kW	12.5 kW	14 kW	15.5 kW	8.5 kW	10 kW	12.5 kW	14 kW	15.5 kW
	Rated input power	1.65 kW	2.02 kW	2.55 kW	2.95 kW	3.41 kW	1.65 kW	2.02 kW	2.55 kW	2.95 kW	3.41 kW
	COP	5.15	4.95	4.90	4.75	4.55	5.15	4.95	4.90	4.75	4.55
Heating (A: 7 / 6°C W: 47 / 55°C)	Capacity	8kW	10 kW	12 kW	14 kW	16 kW	8 kW	10 kW	12 kW	14 kW	16 kW
	Rated input power	2.32 kW	3.08 kW	3.69 kW	4.44 kW	5.16 kW	2.32 kW	3.08 kW	3.69 kW	4.44 kW	5.16 kW
	COP	3.45	3.25	3.25	3.15	3.1	3.45	3.25	3.25	3.15	3.1
Cooling (A: 35°C W: 23 / 18°C)	Capacity	8.5 kW	10 kW	12 kW	14 kW	15.5 kW	8.5 kW	10 kW	12 kW	14 kW	15.5 kW
	Rated input power	1.63	2.13 kW	2.55 kW	3.11 kW	3.56 kW	1.63 kW	2.13 kW	2.55 kW	3.11 kW	3.56 kW
	EER	5.20	4.70	4.70	4.50	4.35	5.20	4.70	4.70	4.50	4.35
Cooling (A: 35°C W: 12 / 7°C)	Capacity	8 kW	9kW	12 kW	13 kW	14 kW	8 kW	9 kW	12 kW	13 kW	14 kW
	Rated input power	2.35 kW	2.81 kW	3.87 kW	4.26 kW	5.09 kW	2.35 kW	2.81 kW	3.87 kW	4.26 kW	5.09 kW
	EER	3.40	3.20	3.10	3.05	2.75	3.40	3.20	3.10	3.05	2.75
Seasonal space heating energy efficiency class ^①	LWT at 35°C	A+++	A+++	A+++	A+++	A+++	A+++	A+++	A+++	A+++	A+++
	LWT at 55°C	A+++	A+++	A+++	A+++	A+++	A+++	A+++	A+++	A+++	A+++
SCOP ^②	LWT at 35°C	5.44	5.30	5.07	4.94	4.90	5.44	5.30	5.07	4.94	4.90
	LWT at 55°C	4.12	4.07	3.89	3.84	3.83	4.12	4.07	3.89	3.84	3.83
Compressor	Type	Rotary DC inverter									
Outdoor fan	Motor type	Brushless DC motor									
	Number of fans	1									
Throttle type		Electronic expansion valve									
Air side heat exchanger	Type	Finned tube									
Water side heat exchanger	Type	Plate type									
Refrigerant	Type/GWP	R290/3									
	Charged volume	1.2 kg	1.2 kg	1.5 kg	1.5 kg	1.5 kg	1.2 kg	1.2 kg	1.5 kg	1.5 kg	1.5 kg
CO2 Equivalent		0.0036 t	0.0036 t	0.0045 t	0.0045 t	0.0045 t	0.0036 t	0.0036 t	0.0045 t	0.0045 t	0.0045 t
Sound power level ^③		49 dB(A)	49 dB(A)	51 dB(A)	52 dB(A)	52 dB(A)	49 dB(A)	49 dB(A)	51 dB(A)	52 dB(A)	52 dB(A)
Sound pressure level at 1m ^④		35 dB(A)	35 dB(A)	37 dB(A)	38 dB(A)	38 dB(A)	35 dB(A)	35 dB(A)	37 dB(A)	38 dB(A)	38 dB(A)
Sound pressure level at 3m ^⑤		32 dB(A)	32 dB(A)	34 dB(A)	35 dB(A)	35 dB(A)	32 dB(A)	32 dB(A)	34 dB(A)	35 dB(A)	35 dB(A)
Dimensions(W x H x D)		1310 x 1050 x 465 mm									
Weight		140kg	140kg	154kg	154kg	154kg	151kg	151kg	165kg	165kg	165kg
Piping connection		G 1-1/4"									
Operation range	Heating	-25 ~ 35 °C									
	Cooling	5 ~ 48 °C									
	DHW	-25 ~ 46 °C									
Water outlet	Heating	25~80 °C									
	Cooling	5~25 °C									
	DHW	25~70 °C									

① Relevant EU standards and legislation: EN14511; EN14825; EN50564; EN12102; (EU) No 811/2013; (EU) No 813/2013; OJ 2014/C 207/02
 ② Seasonal space heating energy efficiency class tests in average climate conditions
 ③ Sound power level test condition: EN12102-1
 ④ Sound pressure level at 1m is the maximum value tested under the condition of A7W55
 ⑤ Sound pressure level at 3m is the maximum value tested under the condition of A7W55

Indoor Unit



STN1-C01



STN1/3-C02



STN1/3-C03

Component	Control Unit	Hydraulic Unit	Hydraulic Integrated Unit
Indoor unit control board	●	●	●
4 inch touch panel	●	●	●
Back up heater		●	●
Expansion tank (8L)		●	●
Solenoid three way valve		●	●
190L hot water tank			●
Hot water tank expansion tank (18L)			●
Hot water tank circulation pump			●
Check valve			●
Application Scenario	Suitable for households with existing or self-installed hydraulic circuits and domestic hot water tanks.	Suitable for households with existing or self-installed domestic hot water tanks	Ideal for new installations or households requiring an upgrade in domestic hot water tank capacity

Control Unit

STN1-C01

Power Supply	220 ~ 240 V / 1N~ / 50 Hz
Rated Current	0.1 A
User Interface	4 inch high-resolution touch panel
Communication	WiFi/Ethernet/RS485
Installation	Wall mounting
Sound power level ^①	30 dB(A)
Sound pressure level ^②	16 dB(A)
Dimensions(W x H x D)	340 x 400 x 80 mm
Weight	6.5 kg

Hydraulic Unit

STN1-C02

STN3-C02

Power Supply	220~240 V / 1N~ / 50 Hz	380 ~ 415 V / 3N~ / 50 Hz
Rated Current	39.5 A	13.5 A
User Interface	4 inch high-resolution touch panel	
Communication	WiFi / Ethernet / RS485	
Back up heater	Capacity combination	3.0 kW + 6.0 kW
	Power supply	220~240 V / 1N~ / 50 Hz
	Rated running current	39.5 A
Expansion tank size ^③	8L	
Piping connections (water) ^④	(G1") / (G1-1/4")	
Recommend circuit breaker	60 A	20 A
Installation	Wall mounting	
Sound power level ^①	33 dB(A)	
Sound pressure level ^②	19 dB(A)	
Dimensions(WxHxD)	420 x 700 x 265 mm	
Weight(Empty)	33 kg	

① Sound power level test condition: EN12102-1

② Sound pressure level is tested under the condition of A7W55

③ The 18L expansion tank is for the DHW, while the 8L one is for the floor heating side

④ G1 connects to indoor water pipe, G1-1/4 connects to outdoor unit water outlet&inlet

Hydraulic Integrated Unit

STN1-C03

STN3-C03

Power Supply	220 ~ 240 V / 1N~ / 50 Hz	380 ~ 415 V / 3N~ / 50 Hz
Rated Current	52.3 A	17.5 A
User Interface	4 inch high-resolution touch panel	
Communication	WiFi / Ethernet / RS485	
Back up heater	Capacity combination	3.0 kW + 6.0 kW
	Power supply	220~240 V / 1N~ / 50 Hz
	Rated running current	39.5 A
Expansion tank size ^④	18 L+8 L	
DHW tank size	190 L	
Piping connections (water) ^③	(G1") / (G1-1/4")	
Recommend circuit breaker	80 A	25 A
Installation	Floor stand	
Sound power level ^①	33 dB(A)	
Sound pressure level ^②	19 dB(A)	
Dimensions(W x H x D)	595 x 1875 x 700 mm	
Weight(empty)	186 kg	

① Sound power level test condition: EN12102-1

② Sound pressure level is tested under the condition of A7W55

③ The 18L expansion tank is for the DHW, while the 8L one is for the floor heating side

④ G1 connects to indoor water pipe, G1-1/4 connects to outdoor unit water outlet&inlet

Solution Diagram

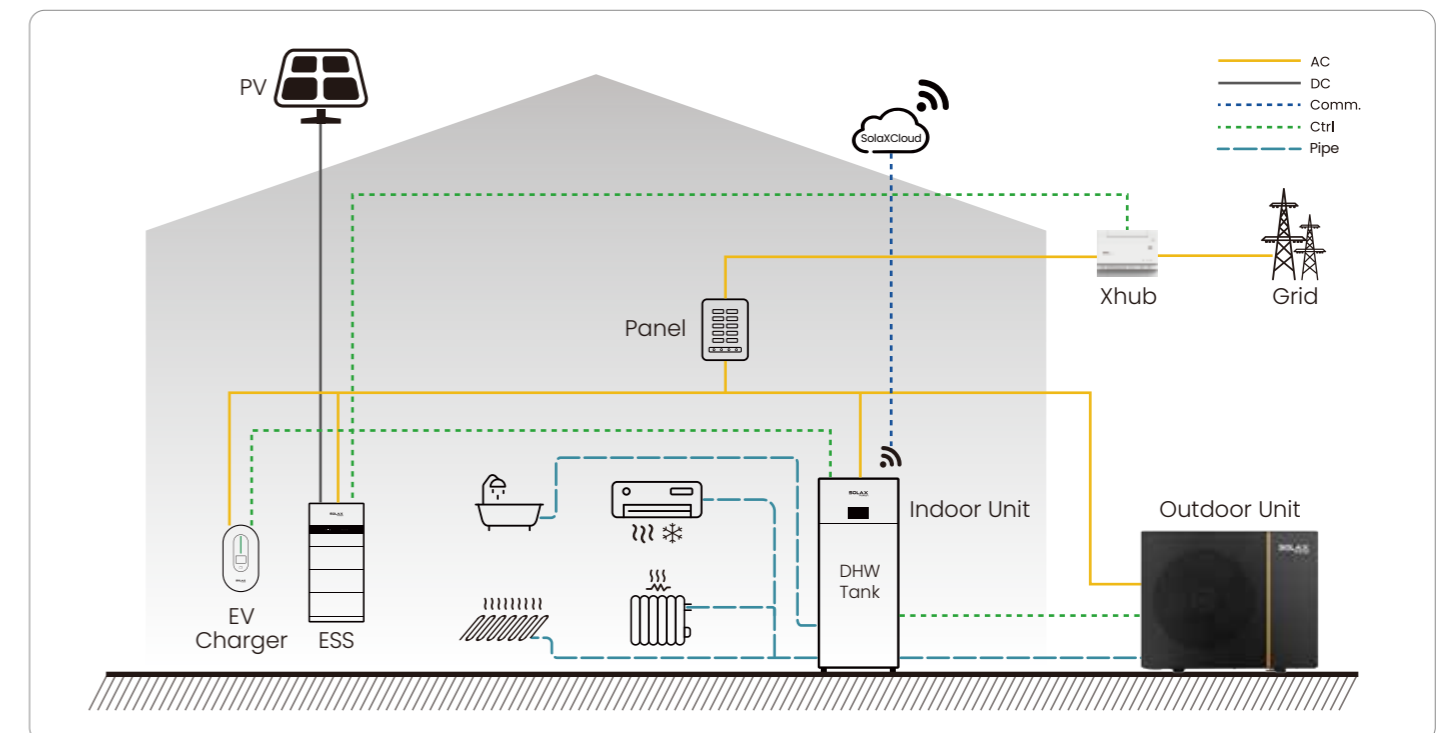

Accessories



Adapter Box G3

Smart Load Manager

Adapter Box G3	
Model	Adapter Box G3
Electrical Parameter	
Power input	12 Vdc, 0.25 A
Power consumption	3 W
Interface	
Communication	3 x RS485
Network connection	WiFi 2.4 GHz / Ethernet 10M
Digital input	4 x DI, 12 V
Digital output	4 x DO, 0 ~ 24 V
Analog output	2 x AO, 0 ~ 10 V
DC output	12 V, 30 mA
HMI interface	LED / APP / Rest button
General Parameters	
Dimensions (L x W x H)	83 mm x 100 mm x 65 mm
Weight	0.2 kg
Operating temperature range	-20 ~ 50°C
Degree of protection	IP20
Installation method	DIN-rail
STANDARD	
Certification	CE LVD, CE EMC, RED, RoHs

High Efficiency

- Multiple load management & balance (heat pump, EV charger, immersion heater...)
- Load consumption monitoring

Flexibility

- Support external control
- Multiple control signal (direct / indirect)

Intelligent

- PV smart distribution
- Multiple work mode
- Smart APP control and OTA upgrade

User-Friendly

- Easy to install with DIN rail design
- WiFi & LAN network connection

Application Diagram

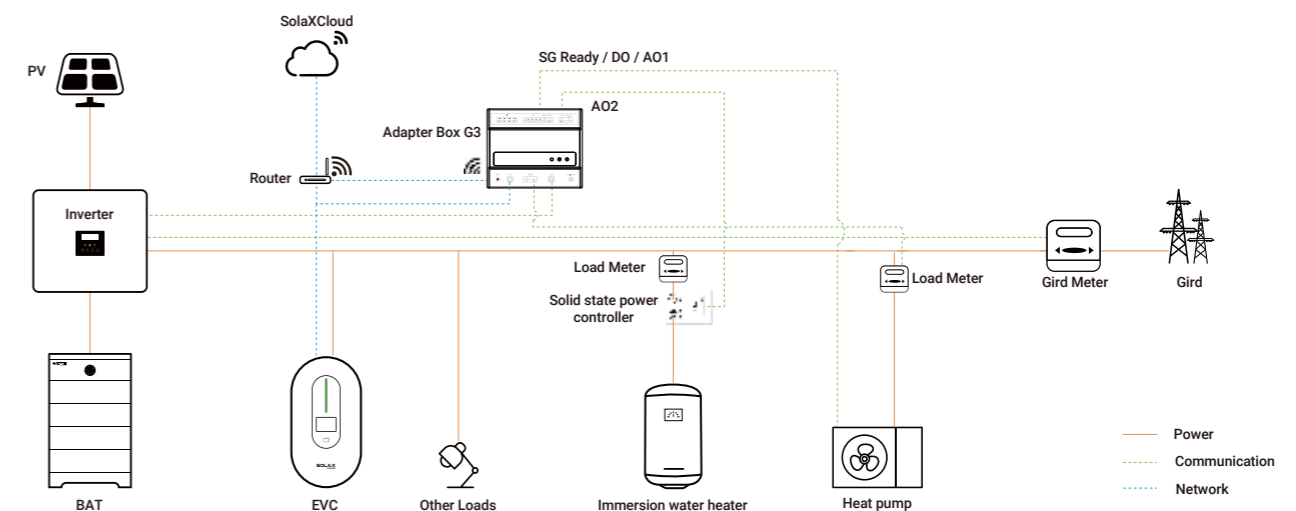



SUCCESS STORIES

SUCCESS STORIES ▶ Selected Global Cases



View More

SUCCESS STORIES ▶ Selected Global Cases



View More



SUCCESS STORIES ▶ Selected Global Cases



View More

📍 ESS-TRENE-261kWh Liquid Cooling 📍 Netherland 📅 3MWh



SUCCESS STORIES ▶ Selected Global Cases



View More

📍 ESS-TRENE-261kWh Liquid Cooling 📍 Netherland 📅 2.6MWh



SUCCESS STORIES ▶ Selected Global Cases



View More

ESS-AELIO 100kWh Air Cooling Italy 100kWh



ESS-AELIO 100kWh Air Cooling Spain 200kWh



SUCCESS STORIES ▶ Selected Global Cases



View More

ESS-TRENE-215kWh Air Cooling Lebanon 645kWh



ESS-TRENE-215kWh Air Cooling China 3MWh



SUCCESS STORIES ▶ Selected Global Cases



View More

📍 ORI 📍 China 📊 5MWh



SUCCESS STORIES ▶ Selected Global Cases



View More

📍 ORI 📍 Netherland 📊 5MWh



SUCCESS STORIES ▶ Selected Global Cases



View More

Smart EV Charger G2 Australia 7kW



Smart EV Charger Czech Republic



SUCCESS STORIES ▶ Selected Global Cases



View More

Fast DC Charger China



SolaX Heat Pump Denmark

